

Alpha Bridge
AQSFP-40G-PSM4-I
Datasheet

Features

- 4 Parallel lanes design
- Up to 11.2Gbps per channel bandwidth
- MPO optical connector
- Compliant with 40G Ethernet IEEE802.3ba and 40GBASE-LR4Standard
- QSFP MSA-compliant
- Up to 2 km transmission
- Compliant with QDR/DDR Infiniband data rates
- Single +3.3V power supply operating
- Built-in digital diagnostic functions
- Temperature range -40°C to 85°C
- RoHS Compliant

Applications

- Infiniband QDR and DDR interconnects
- Datacenters
- Switches and Routers
- 40G BASE-LR4 Ethernet Links

Product Description

AQSFP-40G-PSM4-I is a transceiver module designed for 2Km optical communication applications. The design is compliant with 40GBASE-LR4 of the IEEE P802.3ba standard. It provides increased port density and total system cost savings. The QSFP+ full-duplex optical module offers 4 independent transmit and receive channels, each capable of 10Gb/s operation for an aggregate data rate of 40Gb/son 10km of single-mode fiber.

The product is designed with a form factor, optical/electrical connection, and digital diagnostic interface according to the QSFP Multi-Source Agreement (MSA). It has been designed to meet theharshest external operating conditions including temperature, humidity, and EMI interference.

The module operates from a single +3.3V power supply and LVCMOS/LVTTL global control signals such as Module Present, Reset, Interrupt and Low Power Mode are available with the modules. A 2-wire serial interface is available to send and receive more complex control signals andto obtain digital diagnostic information. Individual channels can be addressed and unused channels can be shut down for maximum design flexibility.

YV-QSFP+P2 is designed with form factor, optical/electrical connection and digital diagnostic interface according to the QSFP Multi-Source Agreement (MSA). It has been designed to meet theharshest external operating conditions including temperature, humidity and EMI interference. The module offers very high functionality and feature integration, accessible via a two-wire serial interface.

Absolute maximum rating

Parameter	Symbol	Min.	Typical	Max.	Unit
Storage Temperature	TS	-40		+85	°C
Supply Voltage	VCCT, R	-0.3		3.6	V
Relative Humidity	RH	0		85	%

Recommended Operating Conditions.

Parameter	Symbol	Min.	Typical	Max.
Case operating Temperature	TC	-40		+85
Supply Voltage	VCCT, R	+3.13	3.3	+3.47
Supply Current	ICC			757
Power Dissipation	PD			2.5

Electrical Characteristics

Parameter	Symbol	Min	Typ	Max	Unit	Note
Data Rate per Channel		-	10.3125	11.2	Gbps	
Power Consumption		-	1.7	2.5	W	

Supply Current	I _{cc}	-	515	757	mA	
Control I/O Voltage-High	V _{IH}	2.0		V _{cc}	V	
Control I/O Voltage-Low	V _{IL}	0		0.7	V	
Transmitter						
Single Ended Output Voltage Tolerance		0.3		4	V	
Common mode Voltage Tolerance		15			mV	
Transmit Input Diff Voltage	V _I	300		1100	mV	
Transmit Input Diff Impedance	Z _{in}	90	100	110	Ω	
Receiver						
Single Ended Output Voltage Tolerance		0.3		4	V	
Rx Output Diff Voltage	V _o	500		800	mV	
Transmit Output Diff Impedance	Z _{out}	90	100	110	Ω	

Optical Characteristics

Parameter	Symbol	Min	Typ	Max	Unit	Ref.
Transmitter						
Center Wavelength	λ _C	1270	1310	1350	nm	
Side-mode Suppression Ratio	SMSR	30	-	-	dB	
Average Launch Power, each Lane	P _{av}	-5.5	-	2.3	dBm	
Optical Modulation Amplitude, each Lane	P _{oma}	-4.5		3.5	dBm	
Difference in Launch Power between anytwo Lanes (OMA)		-	-	5.0	dB	
Launch Power in OMA minus Transmitter and Dispersion Penalty (TDP), each Lane		-9.7	-		dBm	
Extinction Ratio	ER	3.5	-	-	dB	
Transmitter Eye Mask Definition {X1, X2,X3, Y1, Y2, Y3}		{0.25, 0.4, 0.45, 0.25, 0.28, 0.4}				
Optical Return Loss Tolerance		-	-	12	dB	
Average Launch Power OFF Transmitter,each Lane	P _{off}			-30	dBm	
Relative Intensity Noise	R _{in}			-128	dB/HZ	
Transmitter Reflectance		-	-	-12	dB	
Receiver						
Damage Threshold	TH _d	3.0			dBm	
Receiver Reflectance	R _{rx}			-12	dB	
Receiver Sensitivity(OMA), each Lane	SR	-	-	-11.5	dBm	
Difference in Receive Power between anytwo Lanes (OMA)				5.0	dB	
Receive Electrical 3 dB upper Cutoff Frequency, each Lane				12.0	GHz	
LOS De-Assert	LOS _D			-15	dBm	
LOS Assert	LOS _A	-30			dBm	
LOS Hysteresis	LOS _H	0.5			dB	

Diagnostic Monitoring Interface

The digital diagnostics monitoring function is available on all QSFP+ LR4. A 2-wire serial interface provides the user to contact with the module. The structure of the memory is shown in flowing. The memoryspace is arranged into a lower, single page, address space of 128 bytes, and multiple upper address space pages. This structure permits timely access to addresses on the lower page, such as Interrupt Flags and Monitors. Less time-critical time entries, such as serial ID information and threshold settings, are available with the Page Select function. The interface address used is A0xh and ismainly used for time-critical data like interrupt handling in order to enable a one-time read for alldata related to an interrupt situation. After an interrupt, IntL has been asserted, the host can read out the flag field to determine the affected channel and type of flag.

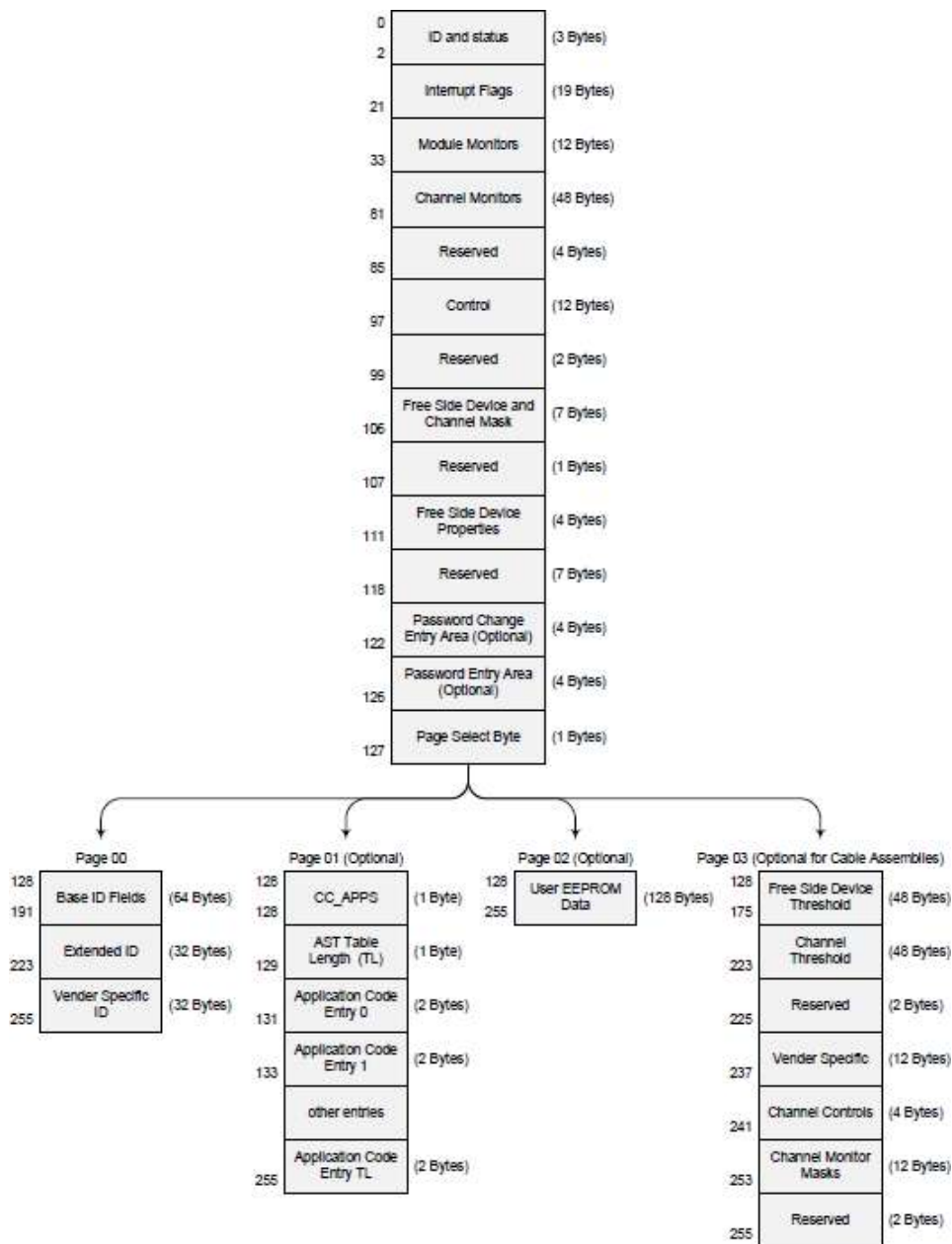

QSFP Memory Map

Serial ID: Data Fields

Address	Size (Bytes)	Name	Description of Base ID Field
Base ID fields			
128	1	Identifier	Identifier Type of serial Module
129	1	Ext. Identifier	Extended Identifier of Serial Module
130	1	Connector	Code for connector type
131-138	8	Specification compliance	Code for electronic compatibility or optical compatibility
139	1	Encoding	Code for serial encoding algorithm
140	1	BR, nominal	Nominal bit rate, units of 100 Mbits/s
141	1	Extended Rate select Compliance	Tags for extended rate select compliance
142	1	Length(SMF)	Link length supported for SMF fiber in km

143	1	Length(OM3 50um)	Link length supported for EBW 50/125um fiber (OM3), units of 2m
144	1	Length(OM2 50um)	Link length supported for 50/125um fiber (OM2), units of 1m
145	1	Length(OM1 62.5 um)	Link length supported for 62.5/125um fiber (OM1), units of 1m
146	1	Length (Copper)	Link length of copper or active cable, units of 1m
147	1	Device tech	Device technology
148-163	16	Vendor name	QSFP+ vendor name(ASCII)
164	1	Extended Module	Extended Module codes for InfiniBand
165-167	3	Vendor OUI	QSFP+ vendor IEEE company ID
168-183	16	Vendor PN	Part number provided by QSFP+ vendor(ASCII)
184-185	2	Vendor rev	Revision level for part number provided by vendor (ASCII)
186-187	2	Wavelength or Copper Cable Attenuation	Nominal laser wavelength (wavelength=value/20 in nm)
188-189	2	Wavelength tolerance	Guaranteed range of laser wavelength (+/- value) from nominal wavelength. (wavelength Tol.=value/200 in nm)
190	1	Max case temp.	Maximum case temperature in degrees C
191	1	CC_BASE	Check code for base ID fields (addresses 128-190)
Extended ID fields			
192-195	4	Options	Rate Select, TX Disable, TX Fault, LOS
196-211	16	Vendor SN	Serial number provided by vendor (ASCII)
212-219	8	Date Code	Vendor's manufacturing date code
220	1	Diagnostic Monitoring Type	Indicates which types of diagnostic monitoring are implemented(if any) in the Module. Bit 1,0 Reserved
221	1	Enhanced Options	Indicates which optional enhanced features are implemented in the transceiver.
222	1	Reserved	
223	1	CC_EXT	Check code for the Extended ID Fields (addresses 192-222)
Vendor-Specific ID Fields			
224-255	32	Vendor Specific EEPROM	

Transceiver Block Diagram

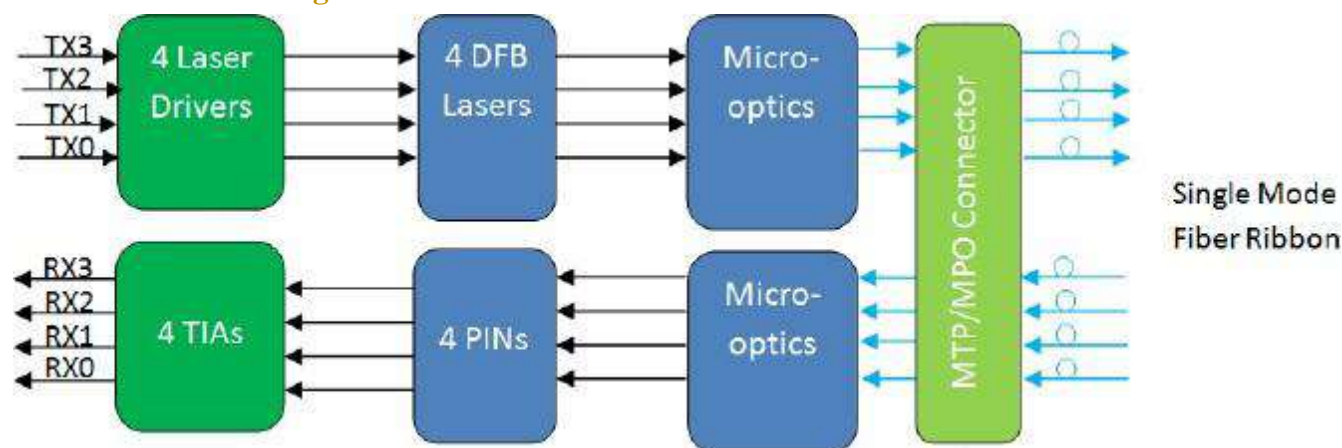

Pin Assignment

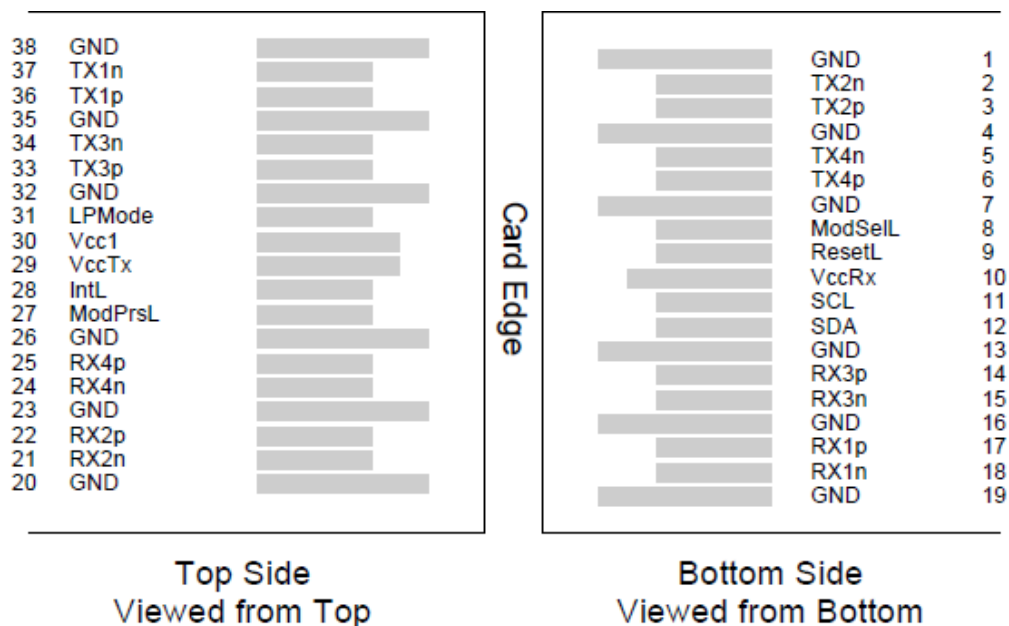

Diagram of Host Board Connector Block Pin Numbers and Name

Pin Description

Pin	Logic	Symbol	Name/Description	Ref.
1		GND	Ground	1
2	CML-I	Tx2n	Transmitter Inverted Data Input	
3	CML-I	Tx2p	Transmitter Non-Inverted Data output	
4		GND	Ground	1
5	CML-I	Tx4n	Transmitter Inverted Data Output	
6	CML-I	Tx4p	Transmitter Non-Inverted Data Output	
7		GND	Ground	1
8	LVTTL-I	ModSelL	Module Select	
9	LVTTL-I	ResetL	Module Reset	
10		VccRx	+3.3V Power Supply Receiver	2
11	LVCMOS-I/O	SCL	2-Wire Serial Interface Clock	
12	LVCMOS-I/O	SDA	2-Wire Serial Interface Data	
13		GND	Ground	1
14	CML-O	Rx3p	Receiver Inverted Data Output	
15	CML-O	Rx3n	Receiver Non-Inverted Data Output	
16		GND	Ground	1
17	CML-O	Rx1p	Receiver Inverted Data Output	
18	CML-O	Rx1n	Receiver Non-Inverted Data Output	
19		GND	Ground	1
20		GND	Ground	1
21	CML-O	Rx2n	Receiver Inverted Data Output	
22	CML-O	Rx2p	Receiver Non-Inverted Data Output	
23		GND	Ground	1
24	CML-O	Rx4n	Receiver Inverted Data Output	
25	CML-O	Rx4p	Receiver Non-Inverted Data Output	
26		GND	Ground	1
27	LVTTL-O	ModPrsL	Module Present	
28	LVTTL-O	IntL	Interrupt	

29		VccTx	+3.3V Power Supply Transmitter	2
30		Vcc1	+3.3V Power Supply	2
31	LVTTL-I	LPMMode	Low Power Mode	
32		GND	Ground	1
33	CML-I	Tx3p	Transmitter Inverted Data Output	
34	CML-I	Tx3n	Transmitter Non-Inverted Data Output	
35		GND	Ground	1
36	CML-I	Tx1p	Transmitter Inverted Data Output	
37	CML-I	Tx1n	Transmitter Non-Inverted Data Output	
38		GND	Ground	1

Notes:

1. GND is the symbol for single and supply(power) common for QSFP modules, All are common within the QSFP module and all module voltages are referenced to this potential otherwise noted. Connect these directly to the host board signal common ground plane. Laser output disabled on TDIS >2.0V or open, enabled on TDIS <0.8V.
2. VccRx, Vcc1, and VccTx are the receiver and transmitter power suppliers and shall be applied concurrently. Recommended host board power supply filtering is shown below. VccRx, Vcc1, and VccTx may be internally connected within the QSFP transceiver module in any combination. The connector pins are each rated for a maximum current of 500mA.

Optical Interface Lanes and Assignment

Below figure shows the orientation of the multi-mode fiber facets of the optical connector
Outside View of the QSFP Module MPO

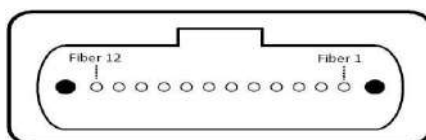

Fiber No.	Lane Assignment
1	RX0
2	RX1
3	RX2
4	RX3
5	Not Used
6	Not Used
7	Not Used
8	Not Used
9	TX3
10	TX2
11	TX1
12	TX0

Recommended Circuit

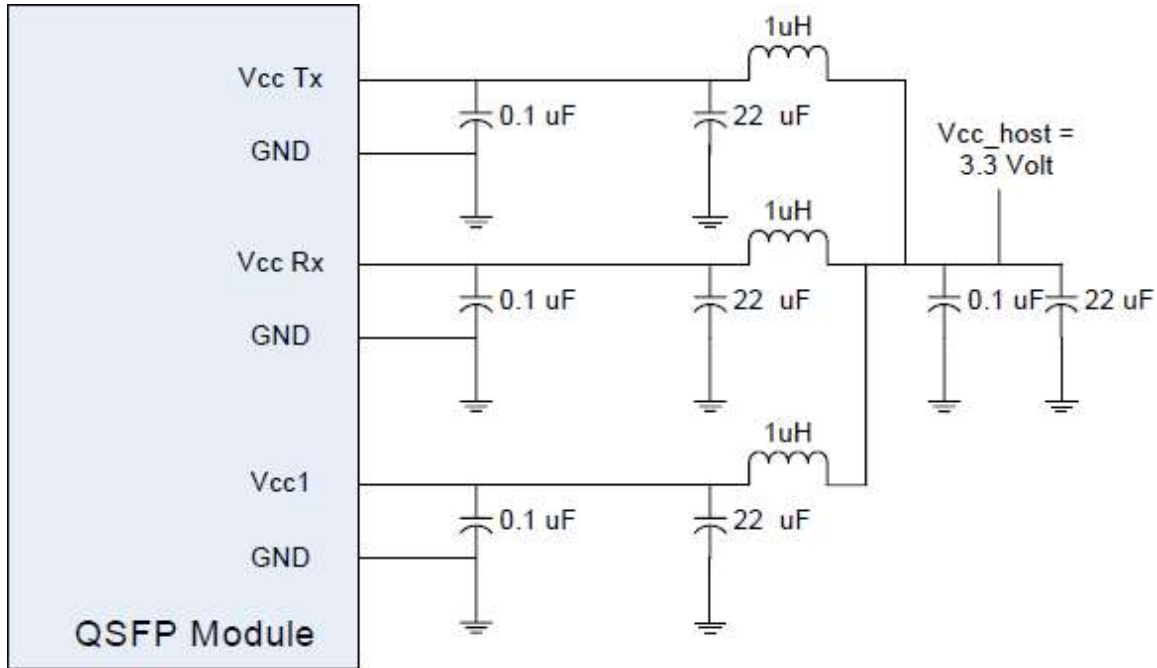

Recommended Host Board Power Supply Filtering

Ordering information

Part Number	Description
AQSFP-40G-PSM4-I	40Gb/s 2km QSFP+ Transceiver Hot Pluggable, MPO Connector, Single mode