

**Alpha Bridge SFP
AQSFP-40G-PLR4
Datasheet**

Features

- 4 Parallel lanes design
- Up to 11.2Gbps data rate per channel
- Aggregate Bandwidth of up to 44.0G
- QSFP+ MSA compliant
- Up to 10km transmission on single mode fiber(SMF)
- Maximum power consumption 3.5W
- Single +3.3V power supply
- Operating case temperature: 0~70°C
- RoHS-6 Compliant

Applications

- 40G Ethernet
- InfiniBand QDR and DDR & SDR
- Datacenter and Enterprise networking

Absolute Maximum Ratings

Parameter	Symbol	Min.	Max.	Units	Note
Storage Temperature	Tc	-40	85	°C	
Supply Voltage	Vcc	-0.5	3.6	V	
Operating Case Temperature	Top	0	70	°C	
Relative Humidity (non- condensation)	RH	5	85	%	
Damage Threshold, each Lane	THd	3.3		dBm	

Recommended Operating Conditions

Parameter	Symbol	Min.	Typ.	Max.	Units	Notes
Operating Case Temperature						
Power Supply Voltage	VCC	3.315	3.3	3.465	V	
Data Rate, each Lane			10.3125	11.2	Gb/s	
Control Input Voltage High		2		Vcc	V	
Control Input Voltage Low		0		0.8	V	
Link Distance with G.652	D	0.002		10	km	

Diagnostics

Parameter	Symbol	Accuracy.	Unites	Notes
Temperature monitor absolute error	DMI_Temp	± 3	°C	Over operating temperature range
Supply voltage monitor absolute error	DMI_VCC	± 0.1	V	Over full operating range
Channel RX power monitor absolute error	DMI_RX_Ch	± 2	dB	1
Channel Bias current monitor	DMI_Ibias_Ch	± 10%	mA	
Channel TX power monitor absolute error	DMI_TX_Ch	± 2	dB	1

Transmitter Electro-optical Characteristics

Parameter	Symbol	Min.	Typ.	Max.	Units	Note
Data Rate		---	10.3125	11.3	Gbps	
Power Consumption			1200	1500	mW	
Output Optical Power	Pout	-3	---	3	dBm	
Center Wavelength	°C	1530		1565	nm	
Relative Intensity Noise	RIN	---	---	-128	dB/Hz	
Side Mode Suppression Ratio	SMSR	30			dB	
Optical spectrum width (-20dB)				1	nm	
Launched power	po	-3		3	dBm	
Launched power in OMA		-2.1	---		dBm	
Extinction Ratio	ER	-6	---		dB	
Transmitter Dispersion Penalty	TDP	---	---	2	dB	1
Average launch power of OFF transmitter	Poff			-30	dBm	
Optical Return Loss Tolerance	RL	21	---		dB	
Single Ended Output Voltage Tolerance		-0.3	---	4	V	
Common mode voltage tolerance		15	---	---	mV	
TX Input Diff Voltage	VI	180		700	mV	
TX Fault	VoL	-0.3		0.4	V	
	Voh	2.0		Vcc+0.3	V	
TX Disable	VoL	vee		Vee+0.8	V	
	Voh	2		Vcc	V	
Data Dependent Input Jitter	DDJ			0.1	UI	
Data Input Total Jitter	TJ			0.28	UI	

Note 1:: Path penalty is intended as the power penalty of the interface between back-to-back and the maximum applied dispersion

Receiver Electro-optical Characteristics

Parameter	Symbol	Min.	Typ.	Max.	Units	Note
Difference in Launch Power between any two lanes (OMA)	Ptx,diff			6.5	dB	
Launch Power in OMA minus Transmitter and Dispersion Penalty (TDP), each Lane		-5.5			dBm	
TDP, each Lane	TDP			3.2	dB	
Extinction Ratio	ER	3.5			dB	
Relative Intensity Noise	RIN			-128	dB/Hz	
Optical Return Loss Tolerance	TOL			12	dB	
Transmitter Reflectance RT	RT			-12	dB	
Average Launch Power OFF Poff	Poff			-30	dBm	
Transmitter Eye Mask Definition {X1,X2,X3,Y1,Y2,Y3}		{0.25,0.4,0.45,0.25,0.28,0.4}				
Average Launch Power OFF Poff	Poff			-30	dBm	

Note 1: Power-on initialization time is the time from when the power supply voltages reach and remain above the minimum recommended operating supply voltages to the time when the module is fully functional.

Note 2: The single-ended input voltage tolerance is the allowable range of the instantaneous input signals.

Note 3: The maximum transmitter average optical power of 1.5 dBm is well within the guard band of receiver overload specifications of commercially available 10GBASE-LR SFP+ transceivers offered.

Note 4: Even if the TDP < 1 dB, the OMA min must exceed the minimum value specified here.

Parameter	Symbol	Min.	Typ.	Max.	Units	Note
Operating Center Wavelength	°C	1250	---	-14.4	dBm	1
Receiver Overload		-1				
Receiver Sensitivity	RSEN					
Receiver Sensitivity in OMA	Psens	---	---	-12.6	dBm	2
Receiver Reflectance	Rf					
Stressed receiver Sensitivity in OMA		---	---	-10.3	dBm	2
Vertical eye closure penalty		2.2			dB	3
LOS Assert	LOSA	-30			Ulp-p	2
LOS De-assert	LOSD	---	---	0.5	dBm	1
LOS Hysteresis	0.5			1.5	dBm	
Stressed eye Jitter	0.3			-12	dB	
Receiver power damage				12	GHz	
Receive electrical 3dB upper cutoff frequency						
Single Ended Output Voltage Tolerance		-3.0	---	---	dBm	
RX Output Diff Voltage	Vo	300		850	mV	
RX Output Rise and Fall Time	Tr/Tf	30			ps	20% to 80%
Total Jitter	TJ			0.7	UI	
Deterministic Jitter	DJ			0.42	UI	

Note 1: The receiver shall be able to tolerate, without damage, continuous exposure to a modulated optical input signal having this power level on one lane. The receiver does not have to operate correctly at this input power.

Block Diagram of Transceiver

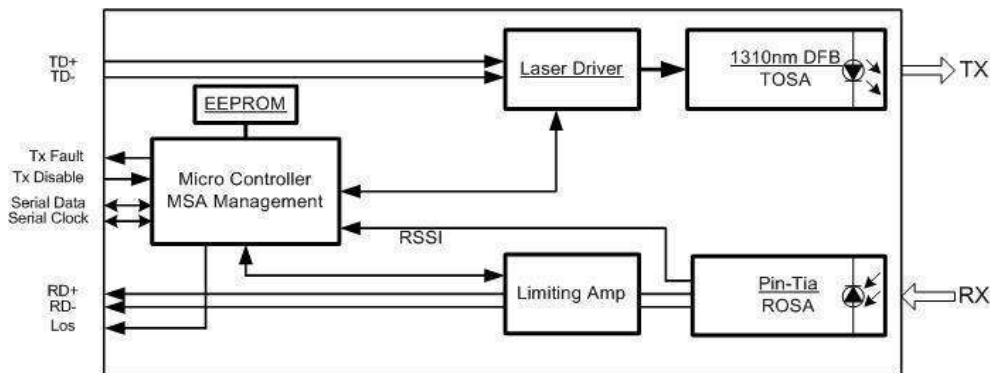

This product is a parallel 40Gb/s Quad Small Form-factor Pluggable (QSFP+) optical module. It provides increased port density and total system cost savings. The QSFP+ full-duplex optical module offers 4 independent transmit and receive channels, each capable of 10Gb/s operation for an aggregate data rate of 40Gb/s on 10km of single mode fiber.

An optical fiber ribbon cable with an MTP/MPO connector can be plugged into the QSFP+ module receptacle. Proper alignment is ensured by the guide pins inside the receptacle. The cable usually cannot be twisted for proper channel to channel alignment. Electrical connection is achieved through a z-pluggable 38-pin connector per MSA requirement.

The module operates with single +3.3V power supply. LVCMOS/LVTTL global control signals, such as Module Present, Reset, Interrupt and Low Power Mode, are available with the modules. A 2-wire serial interface is available to send and receive more complex control signals, and to receive digital diagnostic information.

Individual channels can be addressed and unused channels can be shut down for maximum design flexibility.

The product is designed with form factor, optical/electrical connection and digital diagnostic interface according to the QSFP+ Multi-Source Agreement (MSA). It has been designed to meet the harshest external operating conditions including temperature, humidity and EMI interference. The module can be managed through the I2C two-wire serial interface.

Functional Description

This product is a QSFP+ parallel single mode optical transceiver with an MTP/MPO fiber ribbon connector. The transmitter module accepts electrical input signals compatible with Common Mode Logic (CML) levels. All input data signals are differential and internally terminated. The receiver module converts parallel optical input signals via a photo detector array into parallel electrical output signals. The receiver module outputs electrical signals are also voltage compatible with Common Mode Logic (CML) levels. All data signals are differential and support a data rates up to 10.3Gb/s per channel. Above figure shows the functional block diagram of this roduct.

A single +3.3V power supply is required to power up the module. Both power supply pins VccTx and VccRx are internally connected and should be applied concurrently. Per MSA the module offers 7 low speed hardware control pins (including the 2- wire serial interface): ModSelL, SCL, SDA, ResetL, LPMode, ModPrsL and IntL.

Module Select (ModSelL) is an input pin. When held low by the host, the module responds to 2-wire serial communication commands. The ModSelL allows the use of multiple QSFP+ modules on a single 2-wire interface bus – individual ModSelL lines for each QSFP+ module must be used.

Serial Clock (SCL) and Serial Data (SDA) are required for the 2-wire serial bus communication interface and enable the host to access the QSFP+ memory map.

The ResetL pin enables a complete module reset, returning module settings to their default state, when a low level on the ResetL pin is held for longer than the minimum pulse length. During the execution of a reset the host shall disregard all status bits until the module indicates a completion of the reset interrupt. The module indicates this by posting an IntL (Interrupt) signal with the Data_Not_Ready bit negated in the memory map. Note that on power up (including hot insertion) the module should post this completion of reset interrupt without requiring a reset.

Low Power Mode (LPMode) pin is used to set the maximum power consumption for the module in order to protect hosts that are not capable of cooling higher power modules, should such modules be accidentally inserted.

Module Present (ModPrsL) is a signal local to the host board which, in the absence of a module, is normally pulled up to the host Vcc. When a module is inserted into the connector, it completes the path to ground through a resistor on the host board and asserts the signal. ModPrsL then indicates a module is present by setting ModPrsL to a “Low” state.

Interrupt (IntL) is an output pin. Low indicates a possible module operational fault or a status critical to the host system. The host identifies the source of the interrupt using the 2-wire serial interface. The IntL pin is an open collector output and must be pulled to the Host Vcc voltage on the Host board.

Pin Assignment

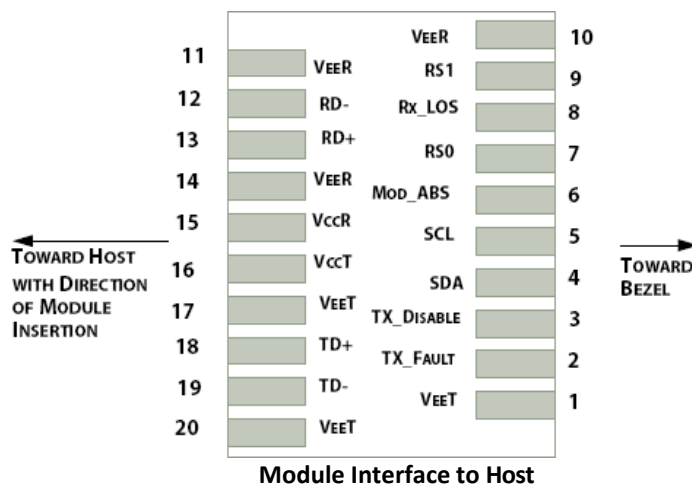

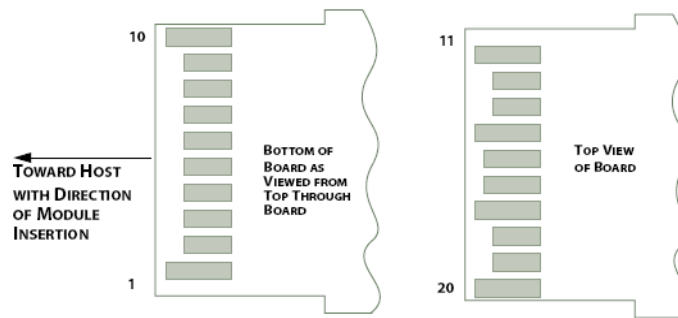

Module Contact Assignment
Pin Descriptions

<i>Pin</i>	<i>Logic</i>	<i>symbol</i>	<i>Name/description</i>	<i>Unites</i>
1		GND	Ground	1
2	CML-I	Tx2n	Transmitter Inverted Data Input	
3	CML-I	Tx2p	Transmitter Non-Inverted Data output	
4		GND	Ground	1
5	CML-I	Tx4n	Transmitter inverted Data Input	
6	CML-I	Tx4p	Transmitter Non-Inverted Data output	
7		GND	Ground	1
8	LVTLL-I	ModSel L	Module Select	
9	LVTLL-I	ResetL	Module Reset	
10		VccRx	+3.3V Power Supply Receiver	2
11	LVC MOS-I/O	SCL	2-Wire Serial Interface Clock	
12	LVC MOS-I/O	SDA	2-Wire Serial Interface Data	
13		GNC	Ground	
14	CML-O	Rx3p	Receiver Non-Inverted Data output	
15	CML-O	Rx3n	Receiver Inverted Data output	
16		GND	Ground	1
17	CML-O	Rx1p	Receiver Non-Inverted Data Output	
18	CML-O	Rx1n	Receiver Inverted Data Output	
19		GND	Ground	1
20		GND	Ground	1
21	CML-O	Rx2n	Receiver Inverted Data output	
22	CML-O	Rx2p	Receiver Non-Inverted Data output	
23		GND	Ground	1
24	CML-O	Rx4n	Receiver Inverted Data output	1
25	CML-O	Rx4p	Receiver Non-Inverted Data output	
26		GND	Ground	1
27	LVTTL-O	ModPrs L	Module Present	
28	LVTTL-O	IntL	Interrupt	
29		VccTx	+3.3V Power Supply transmitter	2
30		Vcc1	+3.3V Power Supply	2
31	LVTTL-I	LPMo d e	Low Power Mode	
32		GND	Ground	1
33	CML-I	Tx3p	Transmitter Non-Inverted Data Input	
34	CML-I	Tx3n	Transmitter Inverted Data Output	
35		GND	Ground	1
36	CML-I	Tx1p	Transmitter Non-Inverted Data Input	
37	CML-I	Tx1n	Transmitter Inverted Data Output	
38		GND	Ground	1

Note:

1. GND is the symbol for signal and supply (power) common for QSFP modules. All are common within the QSFP module and all module voltages are referenced to this potential unless otherwise noted. Connect these directly to the host board signal common ground plane.
2. VccRx, Vcc1 and VccTx are the receiver and transmitter power suppliers and shall be applied concurrently. Recommended host board power supply filtering is shown below. Vcc Rx, Vcc1 and Vcc Tx may be internally connected within the QSFP transceiver module in any combination. The connector pins are each rated for a maximum current of 500mA.

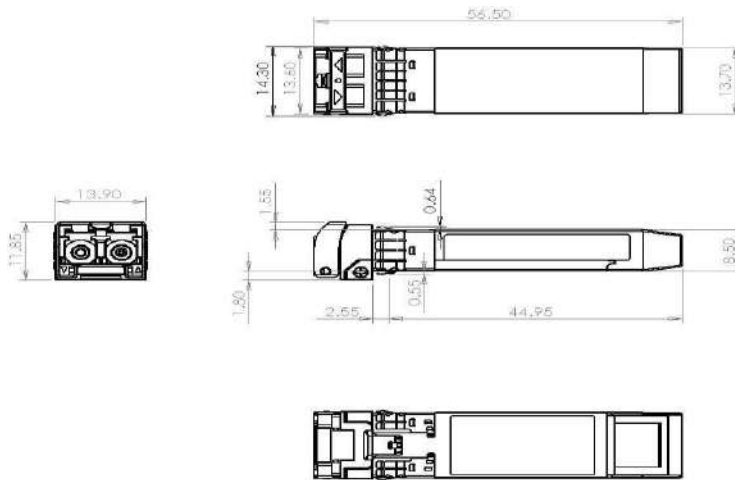
Dimensions



Attention: To minimize MPO connection induced reflections, an MPO receptacle with 8-degree angled end-face is utilized for this product. A female MPO connector with 8-degree end-face should be used with this product as illustrated in Figure 5

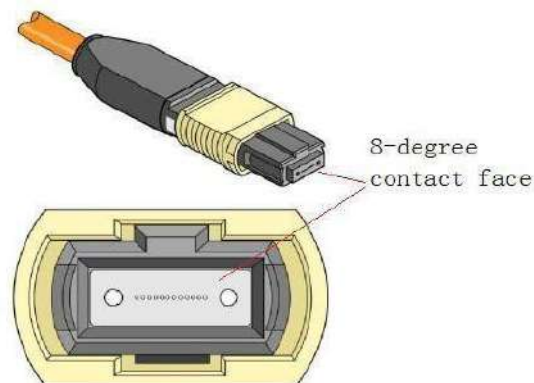

Optical Receptacle Cleaning Recommendations:

All fiber stubs inside the receptacle portions were cleaned before shipment. In the event of contamination of the optical ports, the recommended cleaning process is the use of forced nitrogen. If contamination is thought to have remained, the optical ports can be cleaned using a NTT international Cletop[®] stick type and HFE7100 cleaning fluid. Before the mating of patch-cord, the fiber end should be cleaned up by using Cletop[®] cleaning cassette.

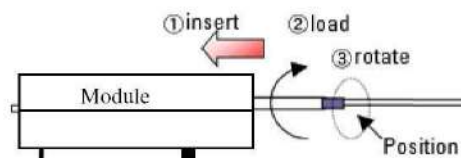
<p>Cleaning of patch-cord</p> 	<p>Cleaning of fiber stub</p>  <ol style="list-style-type: none"> 1. Insert Ensure that stick is held straight when inserting into sleeve. 2. Load Apply sufficient pressure (approx 600-700g) to ensure ferrule a little depressed in sleeve. 3. Rotate Rotate stick clockwise 4-5 times, while ensuring direct contact with ferrule end-face is maintained. <p><i>Notice: Number of possible wipes: Maintenance (repair) ~1 use / piece Equipment construction: 4 uses / piece (max.)</i></p>
--	--

Note: The pictures were extracted from NTT-ME website. And the Cletop[®] is a trademark registered by NTT-ME

Ordering Information

Model Number	Part Number	Voltage	Temperature
AQSFP-40G-PLR4	OPCS-S10-13-CBS	3.3V	0°C to 70 °C

Note: All information contained in this document is subject to change without notice.

Copyright @ Alpha Bridge Technologies Private Limited

This document is ABTPL Public Information. ABTPL reserves the right to alter, update, and otherwise change the information contained in the document from time to time. www.alphabridge.tech