

**Alpha Bridge  
AXFP-10G-ZR+  
Datasheet**





### Features

- Compliant with IEEE802.3ae 10GBASE-ZW/ZR Ethernet
- Compliant with SONET OC-192/SDH STM-64 ITU-T G.959.1 P1L1-2D2
- Compliant with SONET OC-192/SDH STM-64 with ITU-T G.709
- Compliant with 80km 10G Ethernet with ITU-T G.709 FEC
- Compliant with 80km 10G Fiber Channel
- Differential LVPECL inputs and CML outputs
- Compliant with XFP MSA INF-8077i
- TTL signal detect indicator
- Hot Pluggable
- Power consumption < 3.5W
- Class 1 laser product complies with EN 60825-1
- RoHS Compliant

### Absolute Maximum Ratings

Parameter	Symbol	Min	Max	Units	Note
Storage Temperature	$T_s$	-40	85	°C	
Supply Voltage	$V_{cc3}$	-0.5	4.0	V	
Input Voltage	$V_{IN}$	-0.5	6.0	V	

### Recommended Operating Conditions

Parameter	Symbol	Min.	Max.	Units	Note
Case Operating Temperature	$T_c$	0	70	°C	
Supply Voltage	$V_{cc3}$	3.1	3.5	V	
Supply Current	$I_{cc3}$	---	450	mA	
Supply Voltage	$V_{cc5}$	4.5	5.5	V	
Supply Current	$I_{cc5}$	---	400	mA	

### Transmitter Electro-optical Characteristics

$V_{cc3}=3.1\text{ V to }3.5\text{ V}$ ,  $V_{cc5}=4.5\text{ V to }5.5\text{ V}$ ,  $T_c=-5^\circ\text{C to }70^\circ\text{C}$

Parameter	Symbol	Min.	Typ.	Max.	Units	Note
Operating Data Rate		9.95		11.3	Gbps	
Input Reference Clock Rate				Not required		
Output Optical Power	$P_{out}$	1	---	4	dBm	
Extinction Ratio	ER	9			dB	
Center Wavelength	$\lambda_c$	1530		1565	nm	
Sidemode Suppression ratio	SSR <sub>min</sub>	30			dB	
Relative Intensity Noise	RIN	---	---	-130	dB/Hz	
Output Eye	Compliant with IEEE802.3ae					
Differential Input Voltage	$V_{DIFF}$	0.12	---	1.0	V	
Transmit Fault Output-Low	TX_FAULTL	0.0	---	0.5	V	
Transmit Fault Output-High	TX_FAULTH	2.4	---	$V_{cc}$	V	
TX_DISABLE Assert Time	$t_{off}$	---	---	10	μs	
TX_DISABLE Negate Time	$t_{on}$	---	---	2	ms	
Time to initialize	$t_{init}$	---	---	300	ms	
Interrupt assert delay	Interrupt_on	---	---	200	ms	
Interrupt negate delay	Interrupt_off	---	---	500	ms	
P_Down/RST assert delay	P_Down/RST_on			100	ms	
Mod_NR assert delay	Mod_nr_on			1	ms	
Mod_NR negate delay	Mod_nr_off			1	ms	
P-Down reset time		10			μs	
RX_LOS assert delay	$t_{loss\_on}$			100	μs	
RX_LOS negate delay	$t_{loss\_off}$			100	μs	

**Receiver Electro-optical Characteristics**

Vcc3=3.1 V to 3.5 V, Vcc5=4.5 V to 5.5 V, Tc= -5°C to 70°C

Parameter	Symbol	Min	Typical	Max	Unit	Notes
Optical Input Power-maximum	PIN	-7	---	---	dBm	BER < 10 <sup>-12</sup>
Receiver Sensitivity	PIN	---	---	-24	dBm	BER < 10 <sup>-12</sup>
Receiver Sensitivity (OMA)	PIN	---	---	-22.1	dBm	BER < 10 <sup>-12</sup>
Operating Center Wavelength	$\lambda_C$	1270	---	1600	nm	
Receiver Reflectance	Rrx	27			dB	
Dispersion Penalty				3	dB	Up to 80 km
Loss of Signal-Asserted	PA	---	---	-30	dBm	
Loss of Signal-Deasserted	PD	-22	---	---	dBm	
Differential Output Voltage	VDIFF	0.6		0.8	V	
TTL Input High Voltage		2		Vcc	V	
TTL Input Low Voltage		0		0.8	V	
TTL output High Voltage		2.4	---	Vcc	V	
TTL output Low Voltage		0	---	0.4	V	
Receiver Loss of Signal Assert Time (off to on)	tA,RX_LOS	---	---	100	$\mu$ s	
Recover Loss of Signal Assert Time (on to off)	tD,RX_LOS	---	---	100	$\mu$ s	

**Block Diagram of Transceiver**

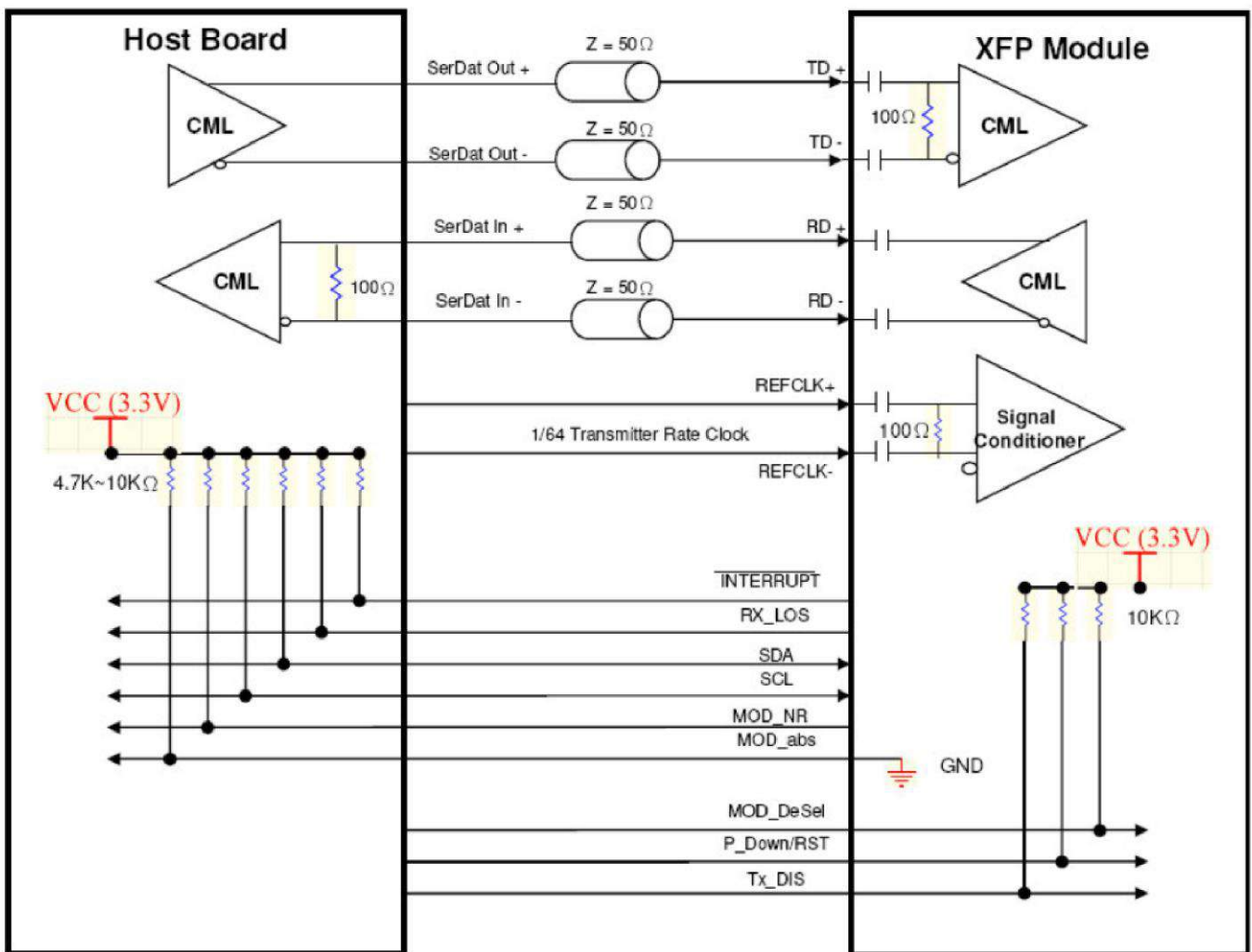

**MOD\_NR**

The Mod\_NR is an output pin that when High, indicates that the module has detected a condition that renders transmitter and or receiver data invalid, shall consist of logical OR of the following signals:

- Transmit Signal Conditioner Loss of Lock
- Transmitter Laser Fault
- Receiver Signal Conditioner Loss of Lock

**MOD\_DESEL**

The Mod\_DeSel is an input pin. When held Low by the host, the module responds to 2-wire serial communication commands. The Mod\_DeSel allows the use of multiple XFP modules on a single 2-wire interface bus. When the Mod\_DesSel pin is “High”, the module shall not respond to or acknowledge any 2-wire interface communication from the host.

**INTERRUPT**

Interrupt is an output pin. When “Low”, indicates possible module operational fault or a status critical to the host system.

**TX\_DIS**

TX\_DIS is an input pin. When TX\_DIS is asserted High, the XFP module transmitter output must be turned off.

**MOD\_ABS**

Mod\_ABS is pulled up to Host\_Vcc on the host board and grounded in the XFP module. Mod\_ABS is then asserted “High” when the XFP module is physically absent from a host slot.

**RX\_LOS**

The RX\_LOS when High indicates insufficient optical power for reliable signal reception.

**P\_DOWN/RST**

This is a multifunction pin for module Power Down and Reset. The P\_Down/RST pin must be pulled up to VCC3 in the XFP module.

**POWER DOWN FUNCTION**

The P\_Down pin, when held high by the host, places the module in the standby (Low Power) mode with a maximum power dissipation of 1.5W. This protects hosts which are not capable of cooling higher power modules which may be accidentally inserted.

**Dimensions**

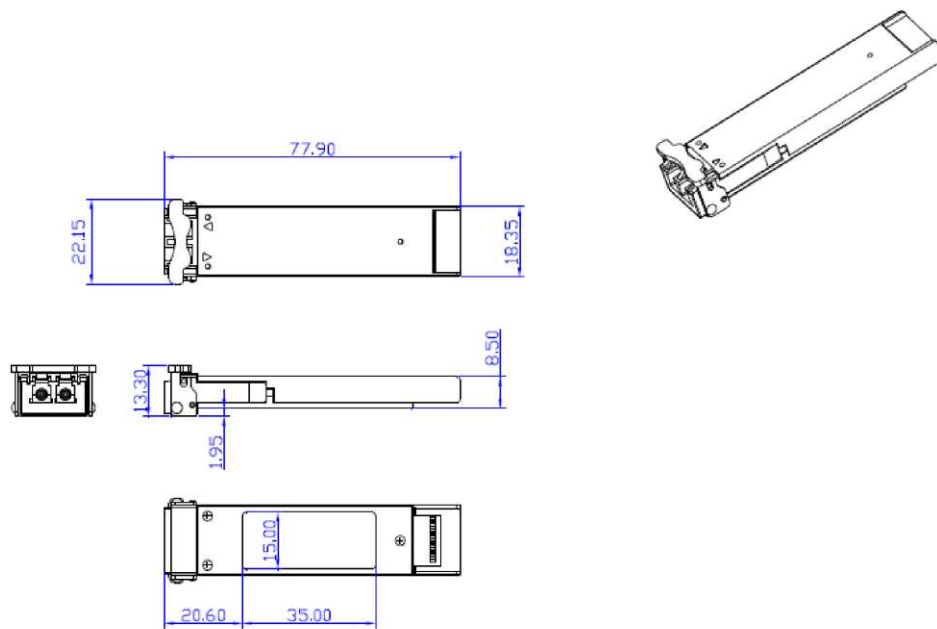

**DIMENSIONS ARE IN MILLIMETERS**

**ALL DIMENSIONS ARE ±0.2mm UNLESS OTHERWISE SPECIFIED**

**Optical Receptacle Cleaning Recommendations**

All fiber stubs inside the receptacle portions were cleaned before shipment. In the event of contamination of the optical ports, the recommended cleaning process is the use of forced nitrogen. If contamination is thought to have remained, the optical ports can be cleaned using a NTT international Cletop® stick type and HFE7100 cleaning fluid. Before the mating of patch-cord, the fiber end should be cleaned up by using Cletop® cleaning cassette.

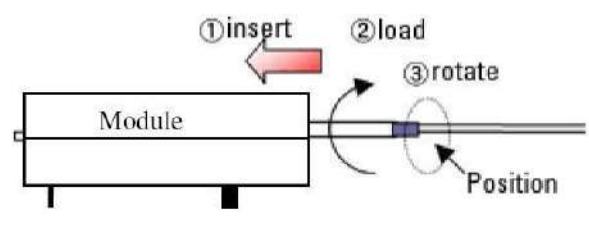
<p><b>Cleaning of patch-cord</b></p> 	<p><b>Cleaning of fiber stub</b></p>  <ol style="list-style-type: none"> <li>1. Insert Ensure that stick is held straight when inserting into sleeve.</li> <li>2. Load Apply sufficient pressure (approx 600-700g) to ensure ferrule a little depressed in sleeve.</li> <li>3. Rotate Rotate stick clockwise 4-5 times, while ensuring direct contact with ferrule end-face is maintained.</li> </ol> <p><i>Notice: Number of possible wipes: Maintenance (repair) ~1 use / piece Equipment construction: 4 uses / piece (max.)</i></p>
---	---

Note: The pictures were extracted from NTT-ME website. And the Cletop® is a trademark registered by NTT-ME

**Ordering Information**

Model Number	Part Number	Reach	Input/Output	Signal Detect	Voltage	Temperature
AXFP-10G-ZR+	OP7K-S10-13-C	25dB	AC/AC	TTL	3.3V	-5 °C to 70 °C

Note: All information contained in this document is subject to change without notice

to alter, update, and otherwise change the information contained in the document from time to time. [www.alphabridge.tech](http://www.alphabridge.tech)