

**Alpha Bridge  
AXFP-10G-LR  
Datasheet**



### Features

- Compliant with XFP-MSA INF-8077i
- Compliant with 10GFC 1200-SM-LL-L Fiber Channel Standard
- Compliant with IEEE802.3ae 10GBASE-LW/LR Ethernet Standard
- Compliant with SONET OC-192 SR-1, SDH STM I-64.1
- Compliant with 10GB over ITU G.709
- Compliant with ITU G.709
- Differential LVPECL inputs and CML outputs
- Single power supply 3.3V
- TTL signal detect indicator
- Hot Pluggable
- Class 1 laser product complies with EN 60825-1
- RoHS Compliant

### Absolute Maximum Ratings

Parameter	Symbol	Min	Max	Units	Note
Storage Temperature	T <sub>s</sub>	-40	85	°C	
Supply Voltage	V <sub>cc3</sub>	-0.5	4.0	V	
Input Voltage	V <sub>IN</sub>	-0.5	V <sub>cc</sub>	V	

### Recommended Operating Conditions

Parameter	Symbol	Min.	Max.	Units	Note
Case Operating Temperature	T <sub>c</sub>	0	70	°C	
Supply Voltage	V <sub>cc3</sub>	3.1	3.5	V	
Supply Current	I <sub>cc3</sub>	---	500	mA	

### Diagnostics

Data Address	Parameter	Range	Accuracy
96-97	Temperature	-35°C to 95°C	±3°C
100-101	Bias Current	0 to 100mA	±10%
102-103	TX Power	-8 to +2.5dBm	±2dB
104-105	RX Power	-16.5 to +1.5dBm	±2dB
106-107	V <sub>cc3</sub> Voltage	2.9~3.7 Volts	±3%

### Transmitter Electro-optical Characteristics

V<sub>cc</sub>=3.1 V to 3.5 V, T<sub>c</sub>= 0°C to 70°C (-25°C to 85°C)

Parameter	Symbol	Min.	Type.	Max.	Units	Note
Operating Data Rate		9.95		11.3	Gbps	
Input Reference Clock Rate				Not required		
Output Optical Power	P <sub>out</sub>	-6	---	-1	dBm	
Extinction Ratio	ER	6			dB	
Center Wavelength	λ <sub>c</sub>	1290		1330	nm	
Sidemode Suppression ratio	SSR <sub>min</sub>	30			dB	
Relative Intensity Noise	RIN	---		-130	dB/Hz	
Output Eye	Compliant with IEEE802.3ae					
Differential Input Voltage	V <sub>DIFF</sub>	0.25	---	1.0	V	
Transmit Fault Output-Low	TX_FAULTL	0.0	---	0.5	V	
Transmit Fault Output-High	TX_FAULTH	2.4	---	V <sub>cc</sub>	V	
TX_DISABLE Assert Time	t <sub>off</sub>	---	---	10	μs	
TX_DISABLE Negate Time	t <sub>on</sub>	---	---	2	ms	
Time to initialize	t <sub>init</sub>	---	---	300	ms	
Interrupt assert delay	Interrupt_on	---	---	200	ms	
Interrupt negate delay	Interrupt_off	---	---	500	ms	
P_Down/RST assert delay	P_Down/RST_on			100	ms	
Mod_NR assert delay	Mod_nr_on			1	ms	
Mod_NR negate delay	Mod_nr_off			1	ms	

P-Down reset time		10			$\mu\text{s}$	
RX_LOS assert delay	t_loss_on			100	$\mu\text{s}$	
RX_LOS negate delay	t_loss_off			100	$\mu\text{s}$	

**Receiver Electro-optical Characteristics**

Vcc=3.1 V to 3.5 V, Tc= 0°C to 70°C (-25°C to 85°C)

Parameter	Symbol	Min	Typical	Max	Unit	Notes
Receiver Sensitivity		-14.4	---	0.5	dBm	BER < 10 <sup>-12</sup>
Receiver Sensitivity (OMA)	PIN	---	---	-12.6	dBm	BER < 10 <sup>-12</sup>
Stress Receiver Sensitivity (OMA)	PIN	---	---	-10.3	dBm	BER < 10 <sup>-12</sup>
Operating Center Wavelength	$\lambda_c$	1270	---	1600	nm	
Optical Return Loss	ORL	12	---	---	dB	
Loss of Signal-Asserted	PA	---	---	-30	dBm	
Loss of Signal-Deasserted	PD	-18	---	---	dBm	
Differential Output Voltage	V <sub>DIFF</sub>	0.5	0.65	0.8	V	
TTL Input High Voltage		2		V <sub>cc</sub>	V	
TTL Input Low Voltage		0		0.8	V	
TTL output High Voltage		2.4	---	V <sub>cc</sub>	V	
TTL output Low Voltage		0	---	0.4	V	
Receiver Loss of Signal Assert Time (off to on)	t <sub>A,RX_LOS</sub>	---	---	100	$\mu\text{s}$	
Recover Loss of Signal Assert Time (on to off)	t <sub>D,RX_LOS</sub>	---	---	100	$\mu\text{s}$	

**Block Diagram of Transceiver**

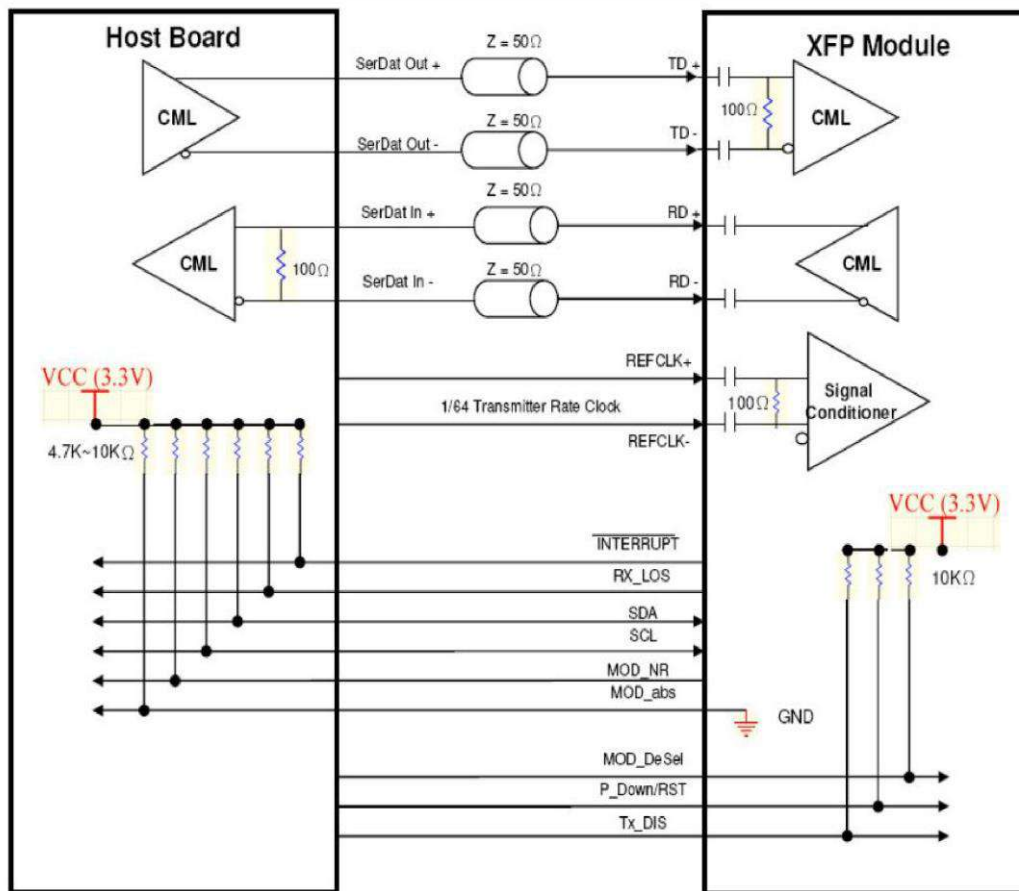

**MOD\_NR**

The Mod\_NR is an output pin that when High, indicates that the module has detected a condition that renders transmitter and or receiver data invalid, shall consist of logical OR of the following signals:

- Transmit Signal Conditioner Loss of Lock
- Transmitter Laser Fault
- Receiver Signal Conditioner Loss of Lock

**MOD\_DESEL**

The Mod\_DeSel is an input pin. When held Low by the host, the module responds to 2-wire serial communication commands. The Mod\_DeSel allows the use of multiple XFP modules on a single 2-wire interface bus. When the Mod\_DesSel pin is “High”, the module shall not respond to or acknowledge any 2-wire interface communication from the host.

**INTERRUPT**

Interrupt is an output pin. When “Low”, indicates possible module operational fault or a status critical to the host system.

**TX\_DIS**

TX\_DIS is an input pin. When TX\_DIS is asserted High, the XFP module transmitter output must be turned off.

**MOD\_ABS**

Mod\_ABS is pulled up to Host\_Vcc on the host board and grounded in the XFP module. Mod\_ABS is then asserted “High” when the XFP module is physically absent from a host slot.

**RX\_LOS**

The RX\_LOS when High indicates insufficient optical power for reliable signal reception.

**P\_DOWN/RST**

This is a multifunction pin for module Power Down and Reset. The P\_Down/RST pin must be pulled up to VCC3 in the XFP module.

**POWER DOWN FUNCTION**

The P\_Down pin, when held high by the host, places the module in the standby (Low Power) mode with a maximum power dissipation of 1.5W. This protects hosts which are not capable of cooling higher power modules which may be accidentally inserted.

**Pin Assignment**

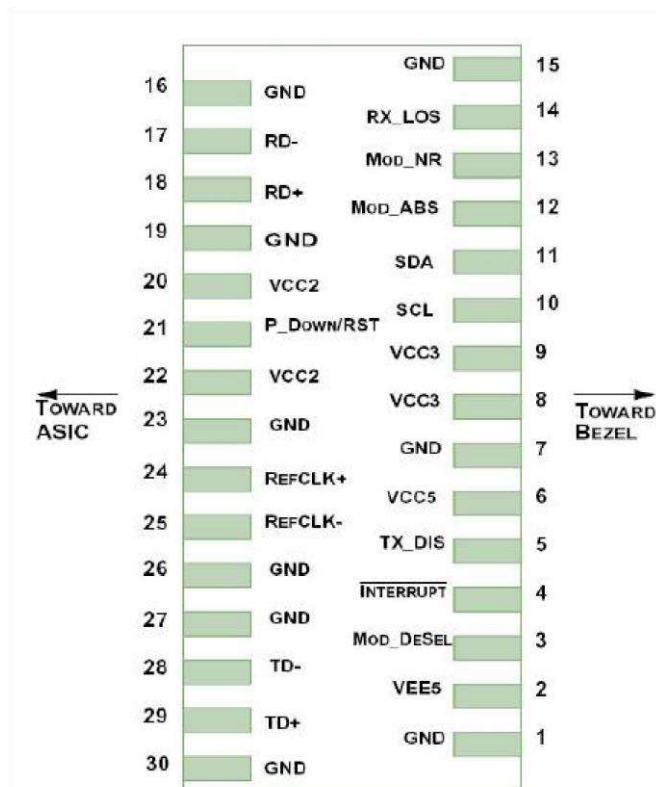

**Pin Description**

PIN	Logic	Symbol	Name/Description	Note
1		GND	Module Ground	1
2		VEE5	Optional -5.2V Power Supply	
3	LVTTTL-I	Mod_DeSel	Module De-select; When held low allows module to respond to 2-wire serial interface	
4	LVTTTL-O	Interrupt	Interrupt; Indicates presence of an important condition which can be read over the 2-wire serial interface	2
5	LVTTTL-I	TX_DIS	Transmitter Disable; Turns off transmitter laser output	
6		VCC5	+5V Power Supply	
7		GND	Module Ground	1
8		VCC3	+3.3V Power Supply	
9		VCC3	+3.3V Power Supply	
10	LVTTTL-I/O	SCL	2-Wire Serial Interface Clock	2
11	LVTTTL-I/O	SDA	2-Wire Serial Interface Data Line	2
12	LVTTTL-O	Mod_Abs	Indicates Module is not present. Grounded in the Module	2
13	LVTTTL-O	Mod_NR	Module Not Ready; Indicating Module Operational Fault	2
14	LVTTTL-O	RX_LOS	Receiver Loss of Signal Indicator	2
15		GND	Module Ground	1
16		GND	Module Ground	1
17	CML-O	RD-	Receiver Inverted Data Output	
18	CML-O	RD+	Receiver Non-Inverted Data Output	
19		GND	Module Ground	1
20		VCC2	+1.8V Power Supply	3
21	LVTTTL-I	P_Down/RST	Power down; When high, requires the module to limit power consumption to 1.5W or below, 2-Wire serial interface must be functional in the low power mode.	
			Reset; The falling edge initiates a complete reset of the module including the 2-wire serial interface, equivalent to a power cycle.	
22		VCC2	+1.8V Power Supply	3
23		GND	Module Ground	1
24	PECL-I	RefCLK+	Not Required	
25	PECL-I	RefCLK-	Not Required	
26		GND	Module Ground	1
27		GND	Module Ground	1
28	CML-I	TD-	Transmitter Inverted Data Input	
29	CML-I	TD+	Transmitter Non-Inverted Data Input	
30		GND	Module Ground	1

**Notes:**

1. Module ground pins Gnd are isolated from the module case and chassis ground within the module.
2. Shall be pulled up with 4.7K-10Kohms to a voltage between 3.15V and 3.45V on the host board.
3. The 1.8V power supply can be optionally programmed to voltages lower than 1.8V in modules supporting the variable power supply.

**Dimensions**

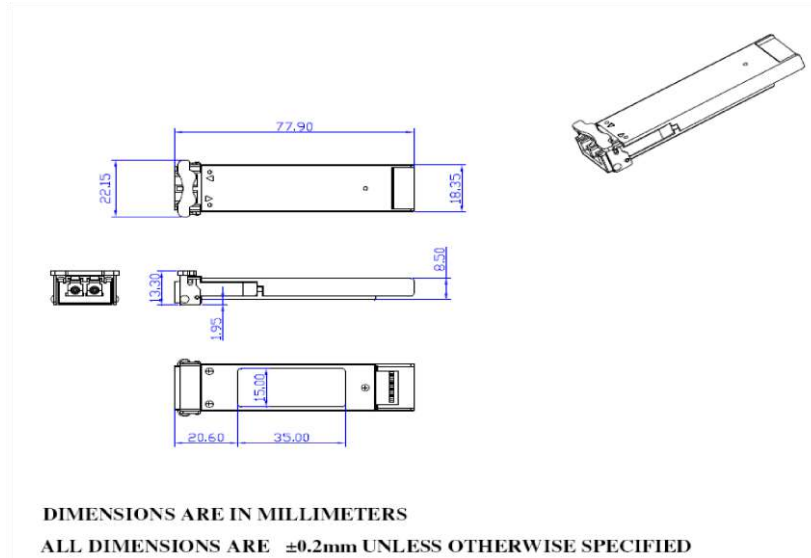

**Optical Receptacle Cleaning Recommendations**

All fiber stubs inside the receptacle portions were cleaned before shipment. In the event of contamination of the optical ports, the recommended cleaning process is the use of forced nitrogen. If contamination is thought to have remained, the optical ports can be cleaned using a NTT international Cletop® stick type and HFE7100 cleaning fluid. Before the mating of patch-cord, the fiber end should be cleaned up by using Cletop® cleaning cassette.

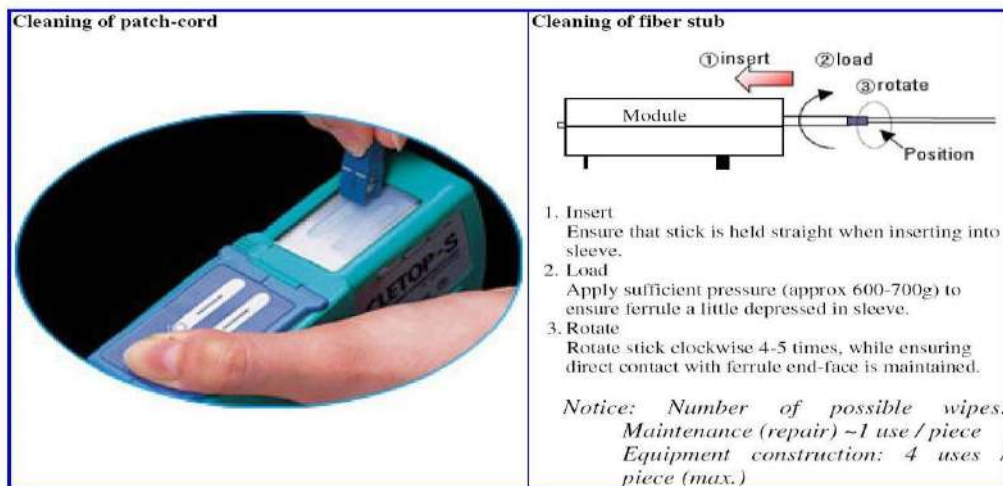

Note: The pictures were extracted from NTT-ME website. And the Cletop® is a trademark registered by NTT-ME

**Ordering Information**

Model Number	Part Number	Reach	Input/Output	Signal Detect	Voltage	Temperature
AXFP-10G-LR	OP7K-S10-13-C	10 km	AC/AC	TTL	3.3V/5V	0°C to 70 °C
AXFP-10G-LR-I	OP7K-S10-13-I	10 km	AC/AC	TTL	3.3V/5V	-25°C to 85 °C

**Note: All information contained in this document is subject to change without notice**

