

**Alpha Bridge
ASFPP-10G-ZR
Datasheet**

+

Features

- Compliant with SFF-8431, SFF-8432 and IEE802.3ae
- G/2G/4G/ 8G/10G Fiber Channel applications.
- Cooled EML transmitter and APD receiver
- Link length from 70km to 80km
- Low Power Dissipation 1.4W Typical (Maximum:2W)
- Single 3.3V power supply
- RoHS6 compliant (lead-free)
- Operating Case Temperature: -5°C to 70°C

Applications

- 10G Ethernet
- 10G Fiber Channel (with/without FEC)

Description

This SFP+ ZR 70~80km1550nm transceiver is a “Limiting Module”, designed for 10G Ethernet and 2G/4G/8G/10G Fiber Channel applications.

The Transceiver consists of two sections: The transmitter section incorporates a cold EML laser. The receiver section consists of an APD photodiode integrated with a TIA. All modules satisfy class I laser safety requirements. Digital Diagnostics Functions are available via a 2-wire serial interface, as specified in SF-8472, which allows real-time access to device operating parameters such as transceiver temperature, laser bias current, transmitted optical power, received optical power, and transceiver supply voltage.

Absolute Maximum Ratings

Parameter	Symbol	Min.	Typ.	Max.	Units	Note
Power Supply Voltage	VCC	-0.5		3.8	V	
Storage Temperature	Tc	-40		85	°C	
Relative Humidity	RH	0		85	%	

Recommended Operating Conditions

Parameter	Symbol	Min	Typ.	Max	Units
Operating Case Temperature	Tc	-5		70	°C
Power Supply Voltage	Vcc	3.13	3.3	3.47	V
Supply Current	Icc		420	610	mA
Module Power Dissipation	Pm		1.4	2	W

Digital Diagnostics Functions

Parameter	Symbol	Accuracy	Unit	Notes
Temperature Monitor Absolute Error	DMI_Temp	± 3	°C	Over operating Temp
Supply Voltage Monitor Absolute Error	DMI_VCC	±0.08	V	Full operating range
TX Power	DMI_TX	± 3 dB	dB	
RX Power	DMI_RX	± 3 dB	dB	-3dBm to -12dBm range
Bias Current Monitor	DMI_Ibias	± 10%	mA	

Optical Characteristics

Parameter	Symbol	Min.	Typ.	Max.	Units	Note
Center Wavelength	λ_t	1530		1565	nm	
Average Optical Power	Po	0		3	dBm	
Side Mode Suppression Ratio	SMSR	30			dB	
Spectral Width (-20dB)	$\Delta\lambda$			0.3	nm	
Relative Intensity Noise	RIN			-128	dB/Hz	
Launch Power of OFF Transmitter	POUT_OFF			-30	dBm	
Extinction Ratio	ER	9			dB	
Optical Return Loss Tolerance	Ori			21	dB	

Receiver						
Input Operating Wavelength	λ	1260		1620	nm	
Receiver Sensitivity Average	R_{sen}			-24	dBm	1
Maximum Input Power	$RX-overload$	-8			dBm	
LOS Asserted	$LOSA$	-34			dBm	
LOS De-Asserted	$LOSD$			-24	dBm	
LOS Hysteresis	$LOSH$	0.5			dB	

Electro Characteristics

Parameter	Symbol	Min.	Typ.	Max.	Units	Note
Data Rate	MRA	0.6	10.3	11.3	Gbps	
Input Differential Impedance	RIN		100		Ω	
Differential Data Input	V_{txDiff}	120		850	mV	
Transmit Disable Voltage	VD	2		$V_{cc3}+0.3$	V	
Transmit Enable Voltage	VEN	0		0.8	v	
Transmit Disable Assert Time	VN			100	us	
Receiver						
Data Rate	MRA	0.6	10.3	11.3	Gbps	
Differential Output Swing	$V_{out P-P}$	350		850	mV	
Rx Output Rise and Fall Time	T_r/T_f	24			ps	
LOS – Asserted	VOA	2		$V_{cc3}+0.3$	V	
LOS – Negated	VOL	0		0.4	V	

Block Diagram of Transceiver

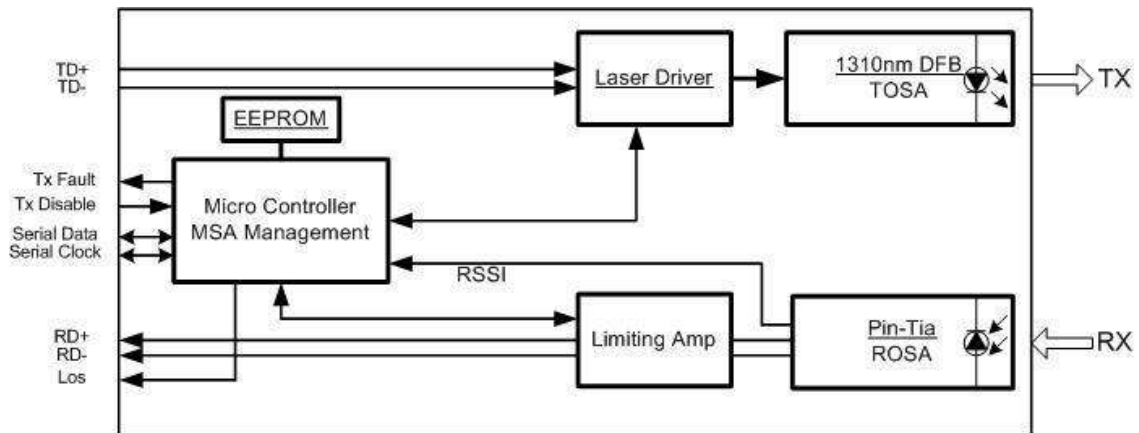

Pin Descriptions

Pin	Symbol	Function/Description	Notes
1	VEET	Transmitter Ground	1
2	Tx_FAULT	Transmitter Fault	2
3	Tx_DIS	Transmitter Disable. Laser output disabled on high or open	3
4	SDA	2-wire Serial Interface Data Line	2
5	SCL	2-wire Serial Interface Clock Line	2
6	MOD_ABS	Module Absent. Grounded within the module	4
7	RS0	Rate Select 0	5
8	RX_LOS	Loss of Signal indication. Logic 0 indicates normal operation	2
9	RS1	Rate Select 1	5
10	VEER	Receiver Ground	1
11	VEER	Receiver Ground	1
12	RD-	Receiver Inverted DATA out. AC Coupled	
13	RD+	Receiver DATA out. AC Coupled	
14	VEER	Receiver Ground	1

15	VCCR	Receiver Power Supply	
16	VCCT	Transmitter Power Supply	
17	VEET	Transmitter Ground	1
18	TD+	Transmitter DATA in. AC Coupled	
19	TD-	Transmitter Inverted DATA in. AC Coupled	
20	VEET	Transmitter Ground	1

Note:

1. Module ground pins GND are isolated from the module case.
2. Shall be pulled up with 4.7K-10KΩ to a voltage between 3.15V and 3.45V on the host board.
3. This open collector/drain output contact shall be pulled up on the host board.
4. Tx_Disable is an input contact with a 4.7kΩ to 10kΩ pull up to VccT inside the module.

Dimensions

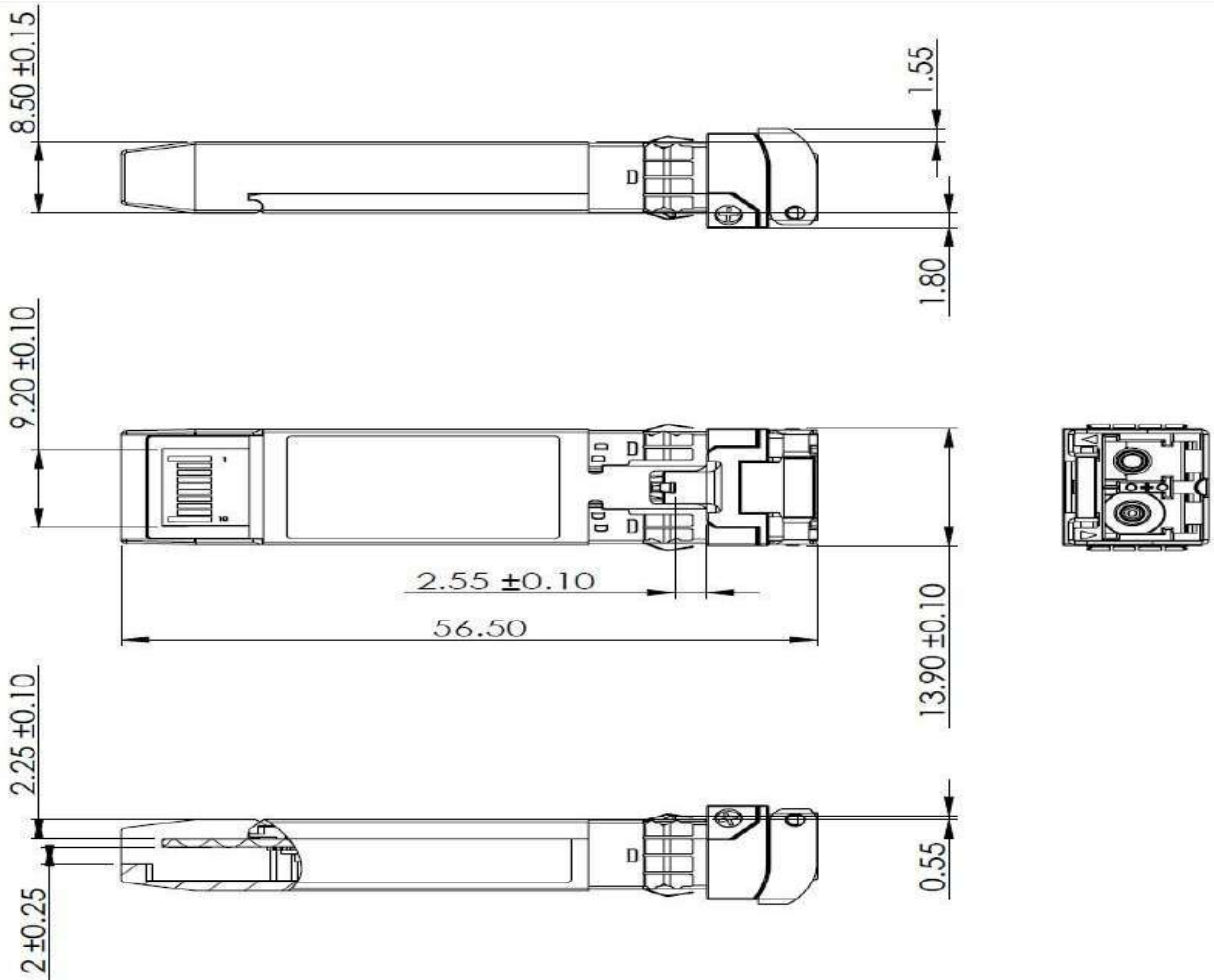

+

Optical Receptacle Cleaning Recommendations:

All fiber stubs inside the receptacle portions were cleaned before shipment. In the event of contamination of the optical ports, the recommended cleaning process is the use of forced nitrogen. If contamination is thought to have remained, the optical ports can be cleaned using a NTT international Cletop® stick type and HFE7100 cleaning fluid. Before the mating of patch-cord, the fiber end should be cleaned up by using Cletop® cleaning cassette.

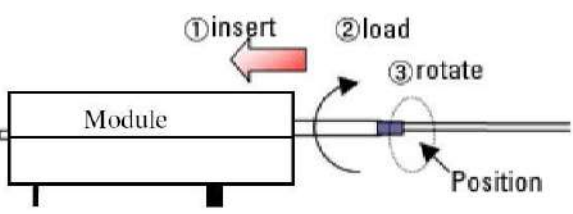
<p>Cleaning of patch-cord</p> 	<p>Cleaning of fiber stub</p>  <ol style="list-style-type: none"> 1. Insert Ensure that stick is held straight when inserting into sleeve. 2. Load Apply sufficient pressure (approx 600-700g) to ensure ferrule a little depressed in sleeve. 3. Rotate Rotate stick clockwise 4-5 times, while ensuring direct contact with ferrule end-face is maintained. <p><i>Notice: Number of possible wipes: Maintenance (repair) ~1 use / piece Equipment construction: 4 uses / piece (max.)</i></p>
---	---

Note: The pictures were extracted from NTT-ME website. And the Cletop® is a trademark registered by NTT-ME

Ordering Information

Model Number	Part Number	Wavelength	Temperature
ASFPP-10G-ZR	OPAK-S80-15-CF	1550nm	-5°C ~70 °C

Note: All information contained in this document is subject to change without notice.

Copyright @ Alpha Bridge Technologies Private Limited

This document is ABTPL Public Information. ABTPL reserves the right to alter, update, and otherwise change the information contained in the document from time to time. www.alphabridge.tech