

**Alpha Bridge  
ASFP28-25G-ER  
Datasheet**



### Features

- Compliant with SFP28 MSA and IEEE 802.33cc25GBASE-ER
- Up to 25.78125Gb/s data links
- 1310nm EML laser and APD photo-detector
- Operating case temperature: 0 to 70°C
- 25G electrical interface (25GAUI/OIF CEI-28G-VSR)
- Reach up to 30km (w/o FEC) or 40km (w/ FEC) over G.652 SMF
- Duplex LC Connector
- Maximum power consumption 1.5W
- Advanced firmware allowing customer system encryption information to be stored in transceiver
- RoHS compliant

### Applications

- High-speed storage area networks
- Custom high-speed data pipes
- 25GE Ethernet
- eCPRI and CPRI

### Description

This 1310 nm EML 25Gb/s SFP28 ER transceiver is designed to transmit and receive optical data over single mode optical fiber for link length up to 30km (w/o FEC) or 40km (w/ FEC) over G.652 SMF. The module optical connection is duplex LC and shall be compatible with SFP+ 28Gbps and backward compatible with legacy 10G SFP+ pluggable. The SFP28 ER IT module is a dual directional device with a transmitter and receiver plus a control management interface (2-wire interface) in the same physical package. 2-wire interface is used for serial ID, digital diagnostics and module control function.

### Absolute Maximum Ratings

Parameter	Symbol	Min.	Max.	Units	Note
Storage Temperature	Tc	-40	85	°C	
Operating Case Temperature	Tc	0	70		
Supply Voltage	Vcc	0	3.6	V	
Relative Humidity	RH	5	85	%	
Damage Threshold	THd	-3		dBm	

### Recommended Operating Conditions

Parameter	Symbol	Min.	Typ.	Max.	Units
Case Operating Temperature	Tc	0		70	°C
Power Supply Voltage	Vcc	3.135	3.3	3.465	V
Data Rate, each Lane			25.78125		Gb/s
Data Rate Accuracy		-100		100	ppm
Link Distance with G.652	D	0.002		40	km

### Digital Diagnostics Functions

Parameter	Symbol	Accuracy	Unit	Notes
Temperature monitor absolute error	DMI_Temp	± 3	°C	Over operating Temp
Supply voltage monitor absolute error	DMI_VCC	±0.1	V	Full operating range
RX power monitor absolute error	DMI_RX	± 2 dB	dB	1

<sup>+</sup> Bias Current monitor	DMI_Ibias	± 10%	mA	
Laser power monitor absolute error	DMI_TX	± 2 dB	dB	1

**Notes:**

1. Due to measurement accuracy of different single mode fibers, there could be an additional +/-1 dB fluctuation, or a +/- 3 dB total accuracy

### Transmitter Electro-optical Characteristics

Parameter	Symbol	Min.	Typ.	Max.	Units	Note
Power Consumption				1.5	W	
Supply Current	I <sub>cc</sub>			450	mA	
Overload Differential Voltage pk-pk	TP1a	900			mV	
Common Mode Voltage (V <sub>cm</sub> )	TP1	-350		2850	mV	1
Differential Termination Resistance Mismatch	TP1			10	%	At 1MHz
Differential Return Loss (SDD11)	TP1	See CEI-28G-VSR Equation 13-19			dB	
Common Mode to Differential conversion and Differential to Common Mode conversion (SDC11, SCD11)	TP1	See CEI-28G-VSR Equation 13-19			dB	
Stressed Input Test	TP1a	See CEI-28G-VSR Section 13.3.11.2.1				
Center Wavelength	λ <sub>t</sub>	1295		1325	nm	
Side Mode Suppression Ratio	SMSR	30			dB	
Average Optical Power	P <sub>avg</sub>	-3		<u>6 / 1</u>	dBm	
OMA	P <sub>OMA</sub>	0		<u>6 / 1</u>	dBm	2
Launch Power in OMA minus Transmitter and Dispersion Penalty (TDP)		-1			dBm	
Transmitter Dispersion Penalty	TDP			2.7	dB	
Extinction Ratio	ER	4			dB	
Relative Intensity Noise	RIN <sub>20OMA</sub>			-130	dB/Hz	
Optical Return Loss Tolerance	TOL			20	dB	
Transmitter Reflectance	R <sub>T</sub>			-26	dB	
Average Launch Power OFF Transmitter	P <sub>off</sub>			-20	dBm	
Eye Mask {X1, X2, X3, Y1, Y2, Y3}		{0.31, 0.4, 0.45, 0.34, 0.38, 0.4}				3

**Note:**

1. V<sub>cm</sub> is generated by the host. Specification includes effects of ground offset voltage.
2. Even if the TDP < 1 dB, the OMA min must exceed the minimum value specified here.
3. Hit ratio 5x10<sup>-5</sup> per sample.

### Receiver Electro-optical Characteristics

Parameter	Symbol	Min.	Typ.	Max.	Units	Note
Differential Voltage, pk-pk	TP4			900	mV	
Common Mode Voltage (V <sub>cm</sub> )	TP4	-350		2850	mV	1
Common Mode Noise, RMS	TP4			17.5	mV	
Differential Termination Resistance Mismatch	TP4			10	%	At 1MHz
Differential Return Loss (SDD22)	TP4	See CEI-28G-VSR Equation 13-19			dB	

Common Mode to Differential conversion and Differential to Common Mode conversion (SDC22, SCD22)	TP4	See CEI-28G-VSR Equation 13-21			dB	
Common Mode Return Loss (SCC22)	TP4			-2	dB	2
Transition Time, 20 to 80%	TP4	12			ps	
Vertical Eye Closure (VEC)	TP4			5.5	dB	
Eye Width at 10 <sup>-15</sup> probability (EW15)	TP4	0.57			UI	
Eye Height at 10 <sup>-15</sup> probability (EH15)	TP4	228			mV	
Center Wavelength	$\lambda_r$	1295		1325	nm	
Damage Threshold	TH <sub>d</sub>	3			dBm	3
Average Receive Power		-21		-4	dBm	4
Receive Power (OMA)				-4	dBm	
Receiver Sensitivity (OMA)	SEN			0.826086957	dBm	for BER =5x10 <sup>-5</sup>
Stressed Receiver Sensitivity (OMA)				-16.5	dBm	
Receiver Reflectance	R <sub>R</sub>			-26	dB	
LOS Assert	LOSA	-30			dBm	
LOS Deassert	LOSD			0.913043478	dBm	
LOS Hysteresis	LOSH	0.5			dB	
Vertical Eye Closure Penalty, each Lane			2.5		dB	
Stressed Eye J2 Jitter			0.27		UI	
Stressed Eye J4 Jitter			0.39		UI	
SRS Eye Mask Definition {X1, X2, X3, Y1, Y2, Y3}		{0.31, 0.4, 0.45, 0.34, 0.38, 0.4}				

**Note:**

1. Vcm is generated by the host. Specification includes effects of ground offset voltage.
2. From 250MHz to 30GHz.
3. The receiver shall be able to tolerate, without damage, continuous exposure to a modulated optical input signal having this power level on one lane. The receiver does not have to operate correctly at this input power.
4. Average receive power (min) is informative and not the principal indicator of signal strength. A received power below this value cannot be compliant; however, a value above this does not ensure compliance.
5. Stressed eye closure, stressed eye J2 Jitter, and stressed eye J4 Jitter are test conditions for measuring stressed receiver sensitivity. They are not characteristics of the receiver.

**Block Diagram of Transceiver**

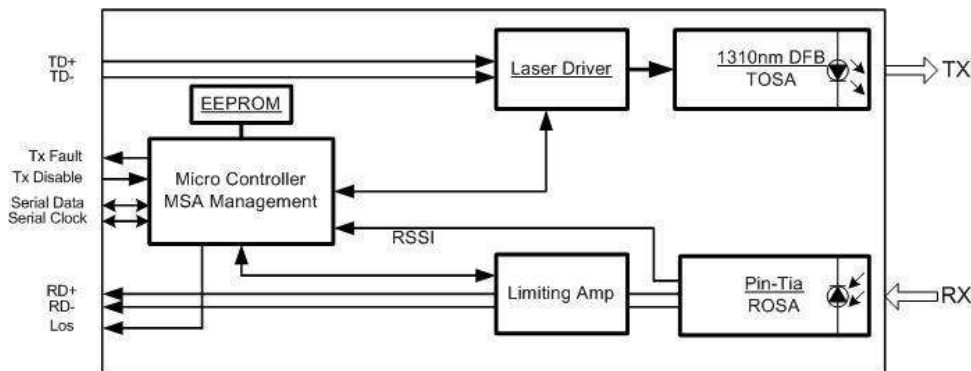

The module operates by a single +3.3V power supply. LVCMOS/LVTTL global control signals, such as Tx\_Fault, Tx\_Disable, are available with the modules. The SFP28 ER IT module electrical interface is compliant to 25GAUI and CEI-VSR-28G-VSR. It has been designed to meet the harshest external operating conditions including temperature, humidity and EMI interference. The module

offers very high functionality and feature integration, accessible via a two-wire serial interface.

The transmitter converts 25Gbit/s serial PECL or CML electrical data into serial optical data compliant with the 25GBASE-LR standard. An open collector compatible Transmit Disable (Tx\_Dis) is provided. Logic “1” or no connection on this pin will disable the laser from transmitting. Logic “0” on this pin provides normal operation. The transmitter has an internal automatic power control loop (APC) to ensure constant optical power output across supply voltage and temperature variations. An open collector compatible Transmit Fault (Tx\_Fault) is provided.

TX\_Fault is module output contact that when high, indicates that the module transmitter has detected a fault condition related to laser operation or safety. The TX\_Fault output contact is an open drain/collector and shall be pulled up to the Vcc\_Host in the host with a resistor in the range 4.7-10 kΩ. TX\_Disable is a module input contact. When TX\_Disable is asserted high or left open, the SFP28 module transmitter output shall be turned off. This contact shall be pulled up to VccT with a 4.7 kΩ to 10 kΩ resistor.

The receiver converts 25Gbit/s serial optical data into serial PECL/CML electrical data. An open collector compatible Loss of Signal is provided. Rx\_LOS when high indicates an optical signal level below that specified in the relevant standard. The Rx\_LOS contact is an open drain/collector output and shall be pulled up to Vcc\_Host in the host with a resistor in the range 4.7-10 kΩ, or with an active termination. Power supply filtering is recommended for both the transmitter and receiver. The Rx\_LOS signal is intended as a preliminary indication to the system in which the SFP28 is installed that the received signal strength is below the specified range. Such an indication typically points to non-installed cables, broken cables, or a disabled, failing or a powered off transmitter at the far end of the cable.

**Pin Assignment**

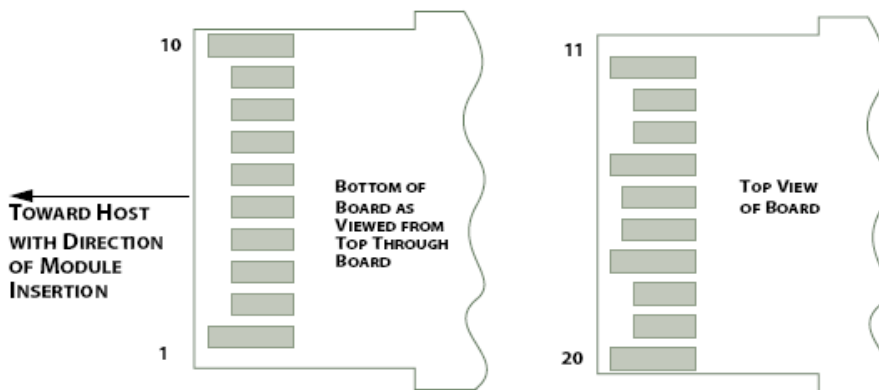
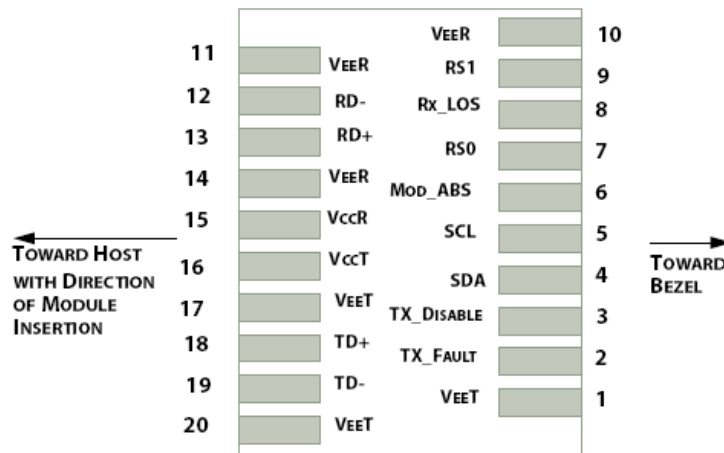

**Pin Descriptions**

PIN	Logic	Symbol	Name / Description	Note
1		VeeT	Module Transmitter Ground	1

2	LVTTTL-O	TX_Fault	Module Transmitter Fault	
3	LVTTTL-I	TX_Dis	Transmitter Disable; Turns off transmitter laser output	
4	LVTTTL-I/O	SDA	2-Wire Serial Interface Data Line	2
5	LVTTTL-I	SCL	2-Wire Serial Interface Clock	2
6		Mod_ABS	Module Absent, connected to VeeT or VeeR in the module	
7	LVTTTL-I	RS0	Receiver Rate Select (not used)	
8	LVTTTL-O	RX_LOS	Receiver Loss of Signal Indication Active LOW	
9	LVTTTL-I	RS1	Transmitter Rate Select (not used)	
10		VeeR	Module Receiver Ground	1
11		VeeR	Module Receiver Ground	1
12	CML-O	RD-	Receiver Inverted Data Output	
13	CML-O	RD+	Receiver Data Output	
14		VeeR	Module Receiver Ground	1
15		VccR	Module Receiver 3.3 V Supply	
16		VccT	Module Receiver 3.3 V Supply	
17		VeeT	Module Transmitter Ground	1
18	CML-I	TD+	Transmitter Non-Inverted Data Input	
19	CML-I	TD-	Transmitter Inverted Data Input	
20		VeeT	Module Transmitter Ground	1

**Notes:**

1. Module ground pins GND are isolated from the module case. 2. Shall be pulled up with 4.7K-10Kohms to a voltage between 3.15V and 3.45V on the host board.
2. Shall be pulled up the voltage between 3.15V and 3.47V with 4.7K – 10Kohms on the host board.

**Dimensions**

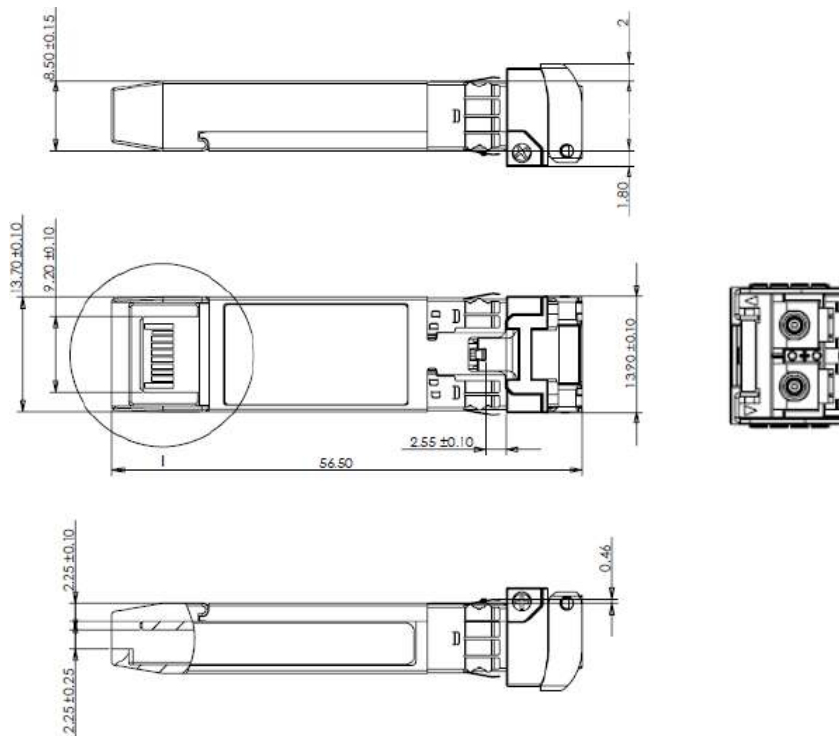

**Optical Receptacle Cleaning Recommendations:**

All fiber stubs inside the receptacle portions were cleaned before shipment. In the event of contamination of the optical ports, the recommended cleaning process is the use of forced nitrogen. If contamination is thought to have remained, the optical ports can be cleaned using a NTT international Cletop<sup>®</sup> stick type and HFE7100 cleaning fluid. Before the mating of patch-cord, the fiber end should be cleaned up by using Cletop<sup>®</sup> cleaning cassette.

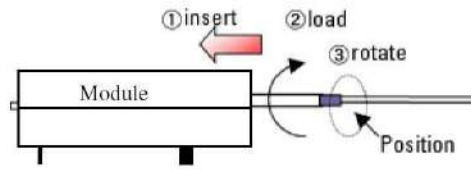
<p><b>Cleaning of patch-cord</b></p> 	<p><b>Cleaning of fiber stub</b></p>  <ol style="list-style-type: none"> <li><b>1. Insert</b> Ensure that stick is held straight when inserting into sleeve.</li> <li><b>2. Load</b> Apply sufficient pressure (approx 600-700g) to ensure ferrule a little depressed in sleeve.</li> <li><b>3. Rotate</b> Rotate stick clockwise 4-5 times, while ensuring direct contact with ferrule end-face is maintained.</li> </ol> <p><i>Notice: Number of possible wipes: Maintenance (repair) ~1 use / piece Equipment construction: 4 uses / piece (max.)</i></p>
--	--

Note: The pictures were extracted from NTT-ME website. And the Cletop<sup>®</sup> is a trademark registered by NTT-ME

**Ordering Information**

Model Number	Part Number	Voltage	Temperature
SFP28-25G-ER	OPAX-S40-13-CB	3.3V	0°C to 70 °C
SFP28-25G-ER	OPAX-S40-13-IB	3.3V	-40°C to 85 °C

Note: All information contained in this document is subject to change without notice.