

Alpha Bridge
ASFP28-25G-3327B-LR
Datasheet

+

Features

- Compliant to IEEE802.3cc 25GBASE-LR
- Up to 25.78 Gb/s data links
- DFB transmitter, PIN photo-detector
- Single LC Connector for bi-directional application
- Electrical interface compliant to SFF-8431 MSA
- 2-wire interface for management specifications compliant with SFF-8472 digital diagnostic monitoring interface for optical transceivers
- Operating case temperature: -40 to 85°C
- All-metal housing for superior EMI performance
- Maximum power consumption 1.5W
- Advanced firmware allow customer system encryption information to be stored in transceiver
- RoHS compliant

Applications

- High-speed storage area networks
- Custom high-speed data pipes
- 25GE Ethernet
- eCPRI and CPRI

Absolute Maximum Ratings

Parameter	Symbol	Min.	Max.	Units
Supply Voltage	Vcc	0	3.6	V
Storage Temperature	T _s	-40	85	°C
Operating Case Temperature	T _i	-40	85	°C
Relative Humidity	RH	0	85	%
Damage Threshold	THd	3.5	-	dBm

Recommended Operating Conditions

Parameter	Symbol	Min.	Typ.	Max.	Units	Notes
Case Operating Temperature	T _c	-40		85	°C	
Power Supply Voltage	Vcc	3.135	3.3	3.465	V	
Data Rate, each Lane		24.3	25.78125		Gb/s	
Data Rate Accuracy		-100		100	ppm	
Control Input Voltage High		2		Vcc	V	
Control Input Voltage Low		0		0.8	V	
Link Distance with G.652	D	0.002		10	km	1

Notes:

1. When long distance is used, it is recommended to use FEC to guarantee the link budget

Digital Diagnostics Functions

Parameter	Symbol	Accuracy	Unit	Notes
Temperature monitor absolute error	DMI_Temp	± 3	°C	Over operating Temp
Laser power monitor absolute error	DMI_TX	± 2 dB	dB	1
RX power monitor absolute error	DMI_RX	± 2 dB	dB	1
Supply voltage monitor absolute error	DMI_VCC	±0.1	V	Full operating range
Bias Current monitor	DMI_Ibias	± 10%	mA	

Notes:

1. Due to measurement accuracy of different single mode fibers, there could be an additional +/-1 dB fluctuation, or a +/- 3 dB total accuracy

+
Transmitter Electro-optical Characteristics

Parameter	Symbol	Min.	Typ.	Max.	Units	Note
Power Consumption				1.5	W	
Supply Current	I _{cc}			450	mA	
Overload Differential Voltage pk-pk	TP1a	900			mV	
Common Mode Voltage (V _{cm})	TP1	-350		2850	mV	1
Differential Termination Resistance Mismatch	TP1			10	%	At 1MHz
Differential Return Loss (SDD11)	TP1	See CEI-28G-VSR Equation 13-19			dB	
Common Mode to Differential conversion and Differential to Common Mode conversion (SDC11, SCD11)	TP1	See CEI-28G-VSR Equation 13-19			dB	
Stressed Input Test	TP1a	See CEI-28G-VSR Section 13.3.11.2.1				
Center Wavelength	λ _t	Ref order information			nm	
Center Wavelength Stability	Δλ _D	-6.5		6.5	nm	
Side Mode Suppression Ratio	SMSR	30			dB	
Average Optical Power	P _{avg}	-7		2	dBm	2
Laser Off Power	P _{off}			-20	dBm	
Optical Modulation Amplitude	OMA	-4		2	dBm	3
Launch power in OMA minus TDP	OMA-TDP	-5			dBm	
Transmitter and dispersion penalty (TDP),	TDP				dB	
Extinction Ratio	ER	3			dB	
Optical Return Loss Tolerance	OTL			20	dB	
Transmitter Reflectance	T _R			-26	dB	
Relative Intensity Noise	RIN _{20OMA}			-130	dB/Hz	
Eye Mask {X1, X2, X3, Y1, Y2, Y3}		{0.31, 0.4, 0.45, 0.34, 0.38, 0.4}				3

Note:

1. V_{cm} is generated by the host. Specification includes effects of ground offset voltage.
2. Even if the TDP < 1 dB, the OMA min must exceed the minimum value specified here.
3. Hit ratio 5x10⁻⁵ per sample.

Receiver Electro-optical Characteristics

Parameter	Symbol	Min.	Typ.	Max.	Units	Note
Differential Voltage, pk-pk	TP4			900	mV	
Common Mode Voltage (V _{cm})	TP4	-350		2850	mV	1
Common Mode Noise, RMS	TP4			17.5	mV	
Differential Termination Resistance Mismatch	TP4			10	%	At 1MHz
Differential Return Loss (SDD22)	TP4	See CEI-28G-VSR Equation 13-19			dB	
Common Mode to Differential conversion and Differential to Common Mode conversion (SDC22, SCD22)	TP4	See CEI-28G-VSR Equation 13-21			dB	
Common Mode Return Loss (SCC22)	TP4			-2	dB	2
Transition Time, 20 to 80%	TP4	9.5			ps	
Vertical Eye Closure (VEC)	TP4			5	dB	
Eye Width at 10 ⁻¹⁵ probability (EW15)	TP4	0.57			UI	
Eye Height at 10 ⁻¹⁵ probability (EH15)	TP4	228			mV	
Center Wavelength	λ _r				nm	

Damage Threshold	TH _d	3			dBm	3
Average Receive Power		-13.3		2	dBm	4
Receive Power (OMA)				-	dBm	
UnStressed Receiver Sensitivity (OMA)	SEN			-11.3	dBm	5
Receiver Reflectance	R _R			-26	dB	
LOS Assert	LOSA	-30			dBm	
LOS Deassert	LOSD			-13	dBm	
LOS Hysteresis	LOSH	0.5			dB	

Note:

1. Vcm is generated by the host. Specification includes effects of ground offset voltage.
2. From 250MHz to 30GHz.
3. The receiver shall be able to tolerate, without damage, continuous exposure to an optical input signal having this average power level.
4. Average receive power (min) is informative and not the principal indicator of signal strength. A received power below this value cannot be compliant; however, a value above this does not ensure compliance.
5. Receiver sensitivity (OMA), (max) is informative. The bit error ratio (BER) shall be less than 5×10^{-5} .

Block Diagram of Transceiver

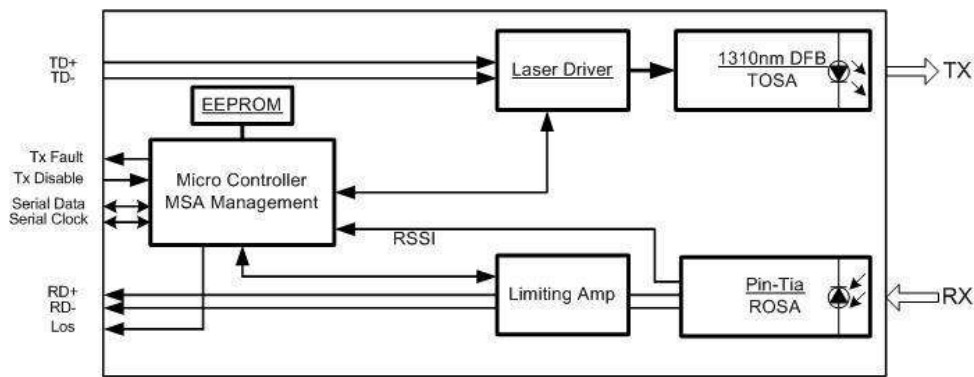

This 25Gb/s SFP28 LR BiDi transceiver is designed to transmit and receive optical data over 10km single mode optical fiber. The module optical connection is single LC connector and shall be compatible with 25G SFP28 pluggable and backward compatible with legacy 10G SFP+ pluggable. The SFP28 LR BiDi module is a dual directional device with a transmitter and receiver plus a control management interface (2-wire interface) in the same physical package. 2-wire interface is used for serial ID, digital diagnostics and module control function.

The module operates by a single +3.3V power supply. The SFP28 LR BiDi module electrical interface is compliant to OFI CEI-VSR-28G-VSR. It has been designed to meet the harshest external operating conditions including temperature, humidity and EMI interference. The module offers very high functionality and feature integration, accessible via a two-wire serial interface.

The transmitter converts 25Gb/s serial PECL or CML electrical data into serial optical data compliant with the 25GBASE-LR standard. An open collector compatible Transmit Disable (Tx_Dis) is provided. Logic "1" or no connection on this pin will disable the laser from transmitting. Logic "0" on this pin provides normal operation. The transmitter has an internal automatic power control loop (APC) to ensure constant optical power output across supply voltage and

+ temperature variations. An open collector compatible Transmit Fault (Tx_Fault) is provided. TX_Fault is module output contact that when high, indicates that the module transmitter has detected a fault condition related to laser operation or safety. The TX_Fault output contact is an open drain/collector and shall be pulled up to the Vcc_Host in the host with a resistor in the range 4.7-10 kΩ. TX_Disable is a module input contact. When TX_Disable is asserted high or left open, the SFP28 module transmitter output shall be turned off. This contact shall be pulled up to VccT with a 4.7 kΩ to 10 kΩ resistor

The receiver converts 25Gb/s serial optical data into serial PECL/CML electrical data. An open collector compatible Loss of Signal is provided. Rx_LOS when high indicates an optical signal level below that specified in the relevant standard. The Rx_LOS contact is an open drain/collector output and shall be pulled up to Vcc_Host in the host with a resistor in the range 4.7-10 kΩ, or with an active termination. Power supply filtering is recommended for both the transmitter and receiver. The Rx_LOS signal is intended as a preliminary indication to the system in which the SFP28 is installed that the received signal strength is below the specified range. Such an indication typically points to non- installed cables, broken cables, or a disabled, failing or a powered off transmitter at the far end of the cable.

Pin Assignment

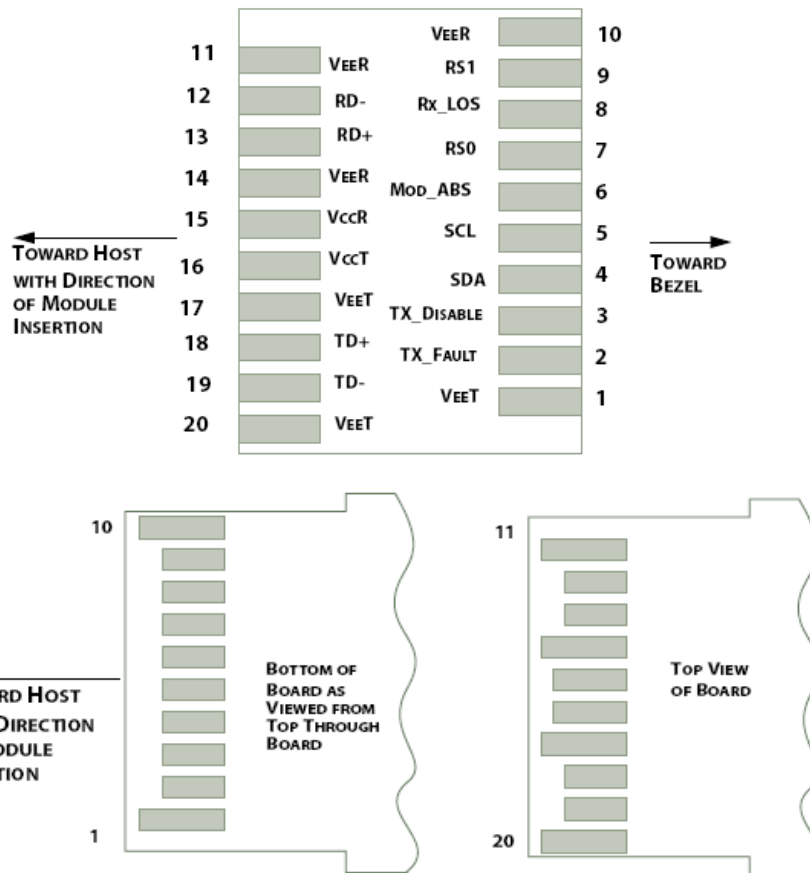

Pin Descriptions

PIN	Logic	Symbol	Name / Description	Note
1		VeeT	Module Transmitter Ground	1

Pin	Signal	Module Pin	Description	Notes
2	LVTTTL-O	TX_Fault	Module Transmitter Fault	
3	LVTTTL-I	TX_Dis	Transmitter Disable; Turns off transmitter laser output	
4	LVTTTL-I/O	SDA	2-Wire Serial Interface Data Line	2
5	LVTTTL-I	SCL	2-Wire Serial Interface Clock	2
6		Mod_ABS	Module Absent, connected to VeeT or VeeR in the module	
7	LVTTTL-I	RS0	Receiver Rate Select (not used)	
8	LVTTTL-O	RX_LOS	Receiver Loss of Signal Indication Active LOW	
9	LVTTTL-I	RS1	Transmitter Rate Select (not used)	
10		VeeR	Module Receiver Ground	1
11		VeeR	Module Receiver Ground	1
12	CML-O	RD-	Receiver Inverted Data Output	
13	CML-O	RD+	Receiver Data Output	
14		VeeR	Module Receiver Ground	1
15		VccR	Module Receiver 3.3 V Supply	
16		VccT	Module Receiver 3.3 V Supply	
17		VeeT	Module Transmitter Ground	1
18	CML-I	TD+	Transmitter Non-Inverted Data Input	
19	CML-I	TD-	Transmitter Inverted Data Input	
20		VeeT	Module Transmitter Ground	1

Notes:

1. Module ground pins GND are isolated from the module case. 2. Shall be pulled up with 4.7K-10Kohms to a voltage between 3.15V and 3.45V on the host board.
2. Shall be pulled up the voltage between 3.15V and 3.47V with 4.7K – 10Kohms on the host board.

Control and Status I/O Timing Characteristics

Timing characteristics of control and status I/O are compatible with SFF-8431-MSA.

Parameter	Symbol	Min.	Max.	Unit	Conditions
Tx_Disable assert time	t _{off}		100	µs	Rising edge of Tx_Disable to fall of output signal below 10% of nominal
Tx_Disable negate time	t _{on}		2	ms	Falling edge of Tx_Disable to rise of output signal above 90% of nominal. This only applies in normal operation, not during start up or fault recovery.
Time to initialize 2-wire interface	t _{2w_start_up}		300	ms	From power on or hot plug after the supply meeting SFF8431
Time to initialize	t _{start_up}		300	ms	From power supplies meeting SFF8431 or hot plug or Tx disable negated during power up, or Tx_Fault recovery, until non-cooled power level I part (or non-cooled power level II part already enabled at power level II for Tx_Fault recovery) is fully operational.
Time to initialize cooled module and time to power up a cooled module to Power Level II	t _{start_up_cooled}		90	s	From power supplies meeting SFF8431 or hot plug, or Tx disable negated during power up or Tx_Fault recovery, until cooled power level I part (or cooled power level II part during fault recovery) is fully operational. Also, from stop bit low-to-high SDA transition enabling Power Level II until cooled module is fully operational
Time to Power Up to Level II	t _{power_level2}		300	ms	From stop bit low-to-high SDA transition enabling power level II until non-cooled module is fully operational
Time to Power Down from Level II	t _{power_down}		300	ms	From stop bit low-to-high SDA transition disabling power level II until module is within power level I requirements
Tx_Fault assert	Tx_Fault_on		1	ms	From occurrence of fault to assertion of Tx_Fault
Tx_Fault assert for cooled module	Tx_Fault_on_cooled		50	ms	From occurrence of fault to assertion of Tx_Fault
Tx_Fault Reset	t _{reset}	10		µs	Time Tx_Disable must be held high to reset Tx_Fault
RS0, RS1 rate select timing for FC	t _{RS0_FC} , t _{RS1_FC}		500	µs	From assertion till stable output
RS0, RS1 rate select timing non FC	t _{RS0} , t _{RS1}		24	ms	From assertion till stable output
Rx_LOS assert delay	t _{los_on}		100	µs	From occurrence of loss of signal to assertion of Rx_LOS
Rx_LOS negate delay	t _{los_off}		100	µs	From occurrence of presence of signal to negation of Rx_LOS

+
Dimensions

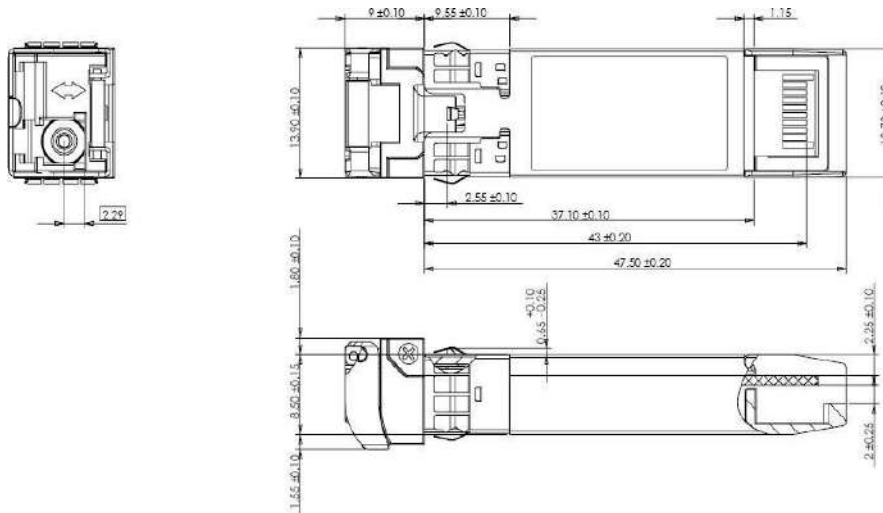

Optical Receptacle Cleaning Recommendations:

All fiber stubs inside the receptacle portions were cleaned before shipment. In the event of contamination of the optical ports, the recommended cleaning process is the use of forced nitrogen. If contamination is thought to have remained, the optical ports can be cleaned using a NTT international Cletop® stick type and HFE7100 cleaning fluid. Before the mating of patch-cord, the fiber end should be cleaned up by using Cletop® cleaning cassette.

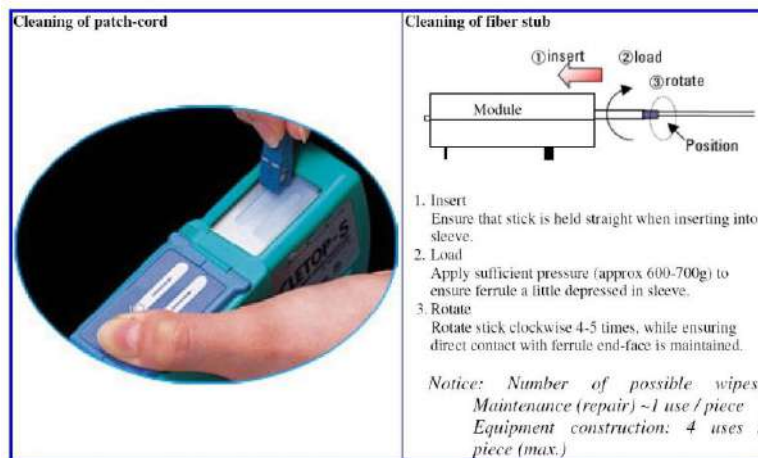

Note: The pictures were extracted from NTT-ME website. And the Cletop® is a trademark registered by NTT-ME

Ordering Information

Model Number	Part Number	Reach	TX/RX	Temperature
ASFP28-25G-3327B-LR	OPAX-W10-27-IB	10 km	1330/1270	0°C to 70 °C
ASFP28-25G-3327B-LR-I	OPAX-W10-27-IB	10 km	1330/1270	-40°C to 85 °C

Note: All information contained in this document is subject to change without notice.

Copyright @ Alpha Bridge Technologies Private Limited

This document is ABTPL Public Information. ABTPL reserves the right to alter, update, and otherwise change the information contained in the document from time to time. www.alphabridge.tech