

**Alpha Bridge
ASFP-1G-eLX5531B
Datasheet**





Features

- Dual data-rate of 1.25Gbps/1.063Gbps operation
- 3.3V single power supply
- 1550nm DFB laser and PIN photodetector for 20km transmission
- Compliant with SFP MSA and SFF-8472 with simplex LC receptacle
- Digital Diagnostic Monitoring:
- Internal Calibration or External Calibration
- Compatible with SONET OC-24-LR-1
- Compatible with RoHS
- Operating Case Temperature:
Standard: 0°C ~70°C
Industrial: -40°C ~85°C

Applications

- Gigabit Ethernet
- Fiber Channel
- Switch to Switch interface
- Switched backplane applications
- Router/Server interface
- Other Optical transmission systems

Description

The SFP-BIDI transceivers are high-performance, cost-effective modules supporting dual data rate of 1.25Gbps/1.0625Gbps and 20km transmission distance with SMF.

The transceiver consists of three sections: a DFB laser transmitter, a PIN photodiode integrated with a trans-impedance preamplifier (TIA) and MCU control unit. All modules satisfy class I laser safety requirements.

The transceivers are compatible with SFP Multi-Source Agreement (MSA) and SFF-8472. For further information, please refer to SFP MSA.

Absolute Maximum Ratings

Parameters	Symbol	Min.	Max.	Units
Supply Voltage	VCC	-0.5	4.5	V
Storage Temperature	T _c	-40	85	°C
Operating Humidity		5	85	%

Recommended Operating Conditions

Parameter	Symbol	Min.	Typ.	Max.	Units
Power Supply Voltage	VCC	3.13	3.3	3.47	V
Power Supply Current	I _{cc}			300	mA
Operating Case Temperature-Standard	TC	0		70	°C
Operating Case Temperature-Industrial	T _c	-40		85	°C
Date Rate - Gigabit Ethernet			1.25		
Date Rate – Fiber Channel			1.063		Gbps

Digital Diagnostic Functions

Parameter/Range	Symbol	Accuracy	Unit	Notes
Temperature/ 0 to 70	DMI_Temp	± 3°C		
Temperature/ -40 to 85	DMI_Temp	± 3°C		
Voltage /3.0 to 3.6	DMI_VCC	±3%	V	
Bias Current Monitor/0 to 100	DMI_Ibias	± 10%	mA	
TX Power /-9 to-3	DMI_TX	± 3 dB	dBm	
RX Power/-23 to -3	DMI_RX	± 3 dB	dBm	

Optical Characteristics

Parameter	Symbol	Min.	Typ.	Max.	Units	Note
Transmitter						
Center Wavelength	λ_C	1530	1550	1570	nm	
Spectral Width (-20dB)	$\Delta\lambda$			1	nm	
Side Mode Suppression Ratio	SMSR	30			dB	
Average Output Power	Pout	-9		-3	dBm	1
Extinction Ratio	ER	9			dB	
Optical Rise/Fall Time (20%~80%)	t_r/t_f			0.26	ns	
Receiver						
Center Wavelength	λ_c	1260		1360	nm	
Receiver Sensitivity				-23	dBm	2
Receiver Overload		-3			dBm	2
LOS Assert	LOSA	-35			dBm	
LOS De-assert	LOSD			-24	dBm	
LOS Hysteresis	LOSH	1		4	dB	

Note 1::

1. The optical power is launched into SMF.
2. Measured with a PRBS 2⁷-1 test pattern @1250Mbps, BER $\leq 1 \times 10^{-12}$.

Electrical Characteristics

Parameter	Symbol	Min.	Typ.	Max.	Units	Note
Transmitter						
Input Differential Impedance	Z_{IN}	90	100	110	Ω	
Data Input Swing Differential	V_{IN}	400		1800	mV	1
Transmit Disable -Disable	V_D	2		Vcc	V	
Transmit Disable - Enable	V_{EN}	0		0.8	V	
Transmit Fault-Fault		2.0		Vcc	V	
Transmit Fault- Normal		0		0.8	V	
Receiver						
Data Output Swing Differential	V_{OUT}	400		1800	mV	2
LOS	High	2		VCC	V	
	Low			0.8	V	

Notes:

1. PECL input, internally AC-coupled and terminated.
2. Internally AC-coupled.

Block Diagram of Transceiver

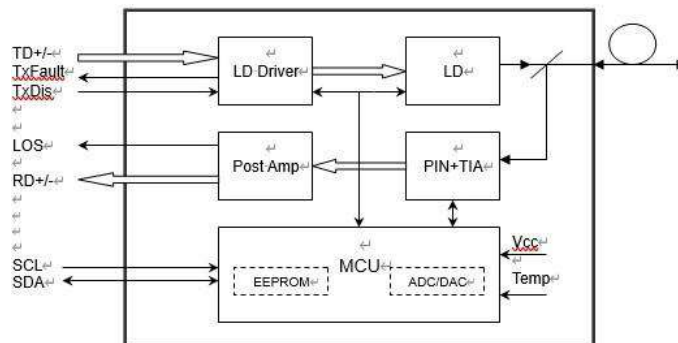

Pin Descriptions

Pin	Symbol	Function/Description	Note
1	VEET	Transmitter Ground	
2	TX FAULT	Transmitter Fault Indication	1
3	TX DISABLE	Transmitter Disable	2
4	MOD_DEF(2)	SDA Serial Data Signal	3
5	MOD_DEF(1)	SCL Serial Clock Signal	3
6	MOD_DEF(0)	TTL Low	3
7	Rate Select	Not Connected	
8	LOS	Loss of Signal	4
9	VEER	Receiver ground	
10	VEER	Receiver ground	
11	VEER	Receiver ground	
12	RD-	Inv. Received Data Out	5
13	RD+	Received Data Out	5
14	VEER	Receiver ground	
15	VCCR	Receiver Power Supply	
16	VCCT	Transmitter Power Supply	
17	VEET	Transmitter Ground	
18	TD+	Transmit Data In	6
19	TD-	Inv. Transmit Data In	6
20	VEET	Transmitter Ground	

Notes:

Plug Seq.: Pin engagement sequence during hot plugging.

- TX Fault is an open collector output, which should be pulled up with a 4.7k~10kΩ resistor on the host board to a voltage between 2.0V and Vcc+0.3V. Logic 0 indicates normal operation; Logic 1 indicates a laser fault of some kind. In the low state, the output will be pulled to less than 0.8V.
- TX Disable is an input that is used to shut down the transmitter optical output. It is pulled up within the module with a 4.7k~10kΩ resistor. Its states are:
 Low (0 to 0.8V): Transmitter on
 (>0.8V, < 2.0V): Undefined
 High (2.0 to 3.465V): Transmitter Disabled
 Open: Transmitter Disabled
- Mod-Def 0,1,2. These are the module definition pins. They should be pulled up with a 4.7k~10kΩ resistor on the host board. The pull-up voltage shall be VccT or VccR.
 Mod-Def 0 is grounded by the module to indicate that the module is present
 Mod-Def 1 is the clock line of two wire serial interface for serial ID
 Mod-Def 2 is the data line of two wire serial interface for serial ID
- LOS is an open collector output, which should be pulled up with a 4.7k~10kΩ resistor. Pull up voltage between 2.0V and Vcc+0.3V. Logic 1 indicates loss of signal; Logic 0 indicates normal operation. In the low state, the output will be pulled to less than 0.8V.
- RD-/+: These are the differential receiver outputs. They are internally AC-coupled 100 differential lines which should be terminated with 100Ω (differential) at the user SERDES.
- TD-/+: These are the differential transmitter inputs. They are internally AC-coupled, differential lines with 100Ω differential termination inside the module.

Dimensions

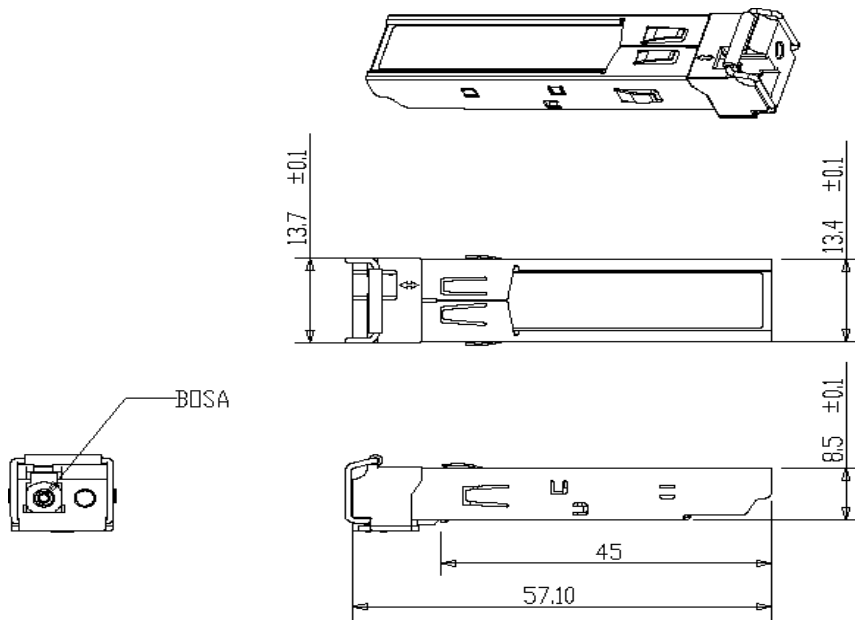

Optical Receptacle Cleaning Recommendations :

All fiber stubs inside the receptacle portions were cleaned before shipment. In the event of contamination of the optical ports, the recommended cleaning process is the use of forced nitrogen. If contamination is thought to have remained, the optical ports can be cleaned using a NTT international Cletop[®] stick type and HFE7100 cleaning fluid. Before the mating of patch-cord, the fiber end should be cleaned up by using Cletop[®] cleaning cassette.

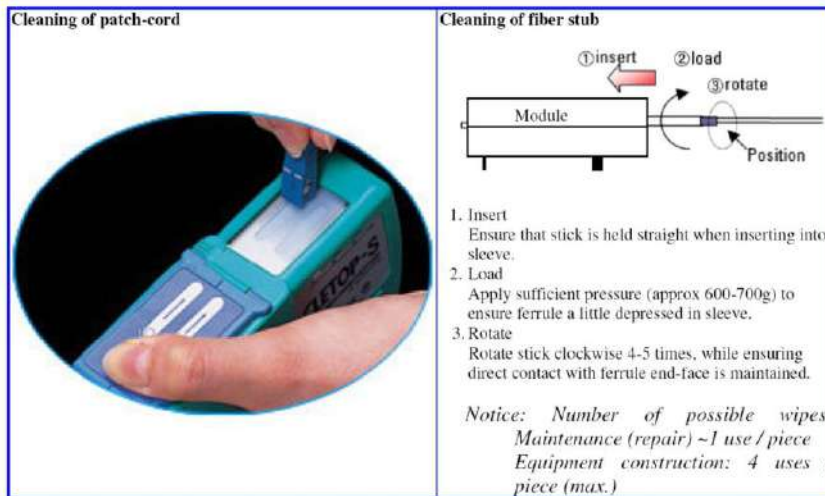

Note: The pictures were extracted from NTT-ME website. And the Cletop[®] is a trademark registered by NTT-ME

Ordering Information

Model Number	Part Number	Reach	TX/RX	Voltage	Temperature
ASFP-1G-eLX5531B	OP6C-W20-B5-CMF	20 km	1550/1310	3.3V	0°C to 70 °C
ASFP-1G- eLX5531B-I	OP6C-W20-B5-IMF	20km	1550/1310	3.3V	-40°C to 85 °C

Note: All information contained in this document is subject to change without notice.