

**Alpha Bridge**  
**AQSFP28-100G-SX4**  
**Datasheet**

### Features

- QSFP28 MSA compliant
- Support 100GE aggregate bit rates
- Support KP4 FEC @100G data rate
- Two independent full-duplex channels
- Up to 100m OM4 MMF transmission
- Operating case temperature: 0 to 70°C
- Single 3.3V power supply
- Maximum power consumption 4W
- LC optical connector
- RoHS-6 compliant

### Applications

- Data Center Interconnect
- 100G Ethernet
- Infiniband HDR

### Description

This product can support 100Gb/s bit rates. It is a parallel Quad Small Form-factor Pluggable (QSFP28) Bi-Direction optical module. The module integrates four host electrical data into two optical lanes (by Dual Wavelength VCSEL Bi-Directional Optical Interface, 850nm and 900nm) to allow optical communication over a 2-fiber duplex LC optical multi-mode fiber. Reversely, on the receiver side, the module de-multiplexes 2 sets of optical input signal and converts them to 4 channels of electrical data.

### Absolute Maximum Ratings

Parameter	Symbol	Min.	Max.	Units	Note
Storage Temperature	$T_s$	-40	85	°C	
Operating Case Temperature	$T_{op}$	10	70	°C	
Power Supply Voltage	$V_{cc}$	-0.5	3.6	V	
Relative Humidity (non-condensation)	$RH$	0	85	%	
Damage Threshold, each Lane	$TH_d$	5		dBm	

### Recommended Operating Conditions

Parameter	Symbol	Min.	Typ.	Max.	Units	Note
Operating Case Temperature	$T_{op}$	10		70	°C	
Power Supply Voltage	$V_{cc}$	3.135	3.3	3.465	V	
Data Rate Accuracy		-100		100	ppm	
Pre-FEC Bit Error Ratio				2.4x10 <sup>-4</sup>		
Post-FEC Bit Error Ratio				1x10 <sup>-12</sup>		1
Control Input Voltage High		2		$V_{cc}$	V	
Control Input Voltage Low		0		0.8	V	
Link Distance	OM3			70	m	2
	OM4			100	m	2
	OM5			150	m	2

**Notes:**

1. FEC provided by host system.
2. FEC required on host system to support maximum distance.

**Diagnostics Monitoring**

Parameter	symbol	Accuracy	Unit	Notes
Temperature monitor absolute error	Dmi_Temp	±3	°C	Over operating temperature range
Supply Voltage Monitor absolute error	Dmi_VCC	±0.15	V	overfull operating range
Channel Rx power monitor absolute error	Dmi_RX_Ch	± 2	Db	1
Channel Bias Current monitor	Dmi_lbias_Ch	± 10%	Ma	
channel TX power monitor absolute error	Dmi_TX_Ch	± 2	dB	1

**Notes:**

1. Due to the measurement accuracy of different single-mode fibers, there could be an additional +/-1 dB fluctuation or a +/- 3 dB total accuracy.

**Optical Characteristics**

Parameter	Symbol	Min.	Typ.	Max.	Units	Note
Center Wavelength Line0	$\lambda_C$	844	850	863	nm	
Center Wavelength Line1	$\lambda_C$	900	910	918	nm	
<b>Transmitter</b>						
RMS Spectral Width	$\Delta\lambda_{rms}$	$\lambda_1:0.6 \lambda_2: 0.65$			nm	
Average Launch Power, each lane	<i>PAVG</i>	-6.2		4	dBm	
Optical Modulation						
Amplitude (OMA outer), each lane	<i>POMA</i>	-4.2		3	dBm	1
Peak Power, each Lane				--	dBm	
Launch power in OMA minus TDP, each lane		-5.6			dBm	
TDECQ, each lane				4.5	dB	
Extinction Ratio	<i>ER</i>	3			dB	
Transmitter transition time, each lane				31	ps	
RIN 12 OMA				-128	dB/Hz	
Optical Return Loss Tolerance	<i>TOL</i>			12	dB	
Average Launch Power of OFF Transmitter, each Lane	<i>Poff</i>			-30	dBm	
Encircled Flux		≥ 86% at 19 $\mu$ m				
		≥ 30% at 4.5 $\mu$ m				2
Signaling rate, each lane		26.5625 ± 100ppm			Gbps	
<b>Receiver</b>						
Damage Threshold, each Lane	<i>THd</i>	5			dBm	3
Average Receiver Power, each Lane		-8.2			dBm	4
Average power at receiver input, each lane (overload)				4	dBm	
Receiver Reflectance	<i>RR</i>			-12	dB	

Stressed receiver sensitivity in OMA Lane2				-3.5	dBm	5
Receiver sensitivity (OMA outer), each lane				Max (-6.6, SECQ-8) as per IEEEcl150	dBm	
LOS Assert	LOSA	-30		-14.2	dBm	
LOS Deassert	LOSD			-11.2	dBm	
LOS Hysteresis	LOSH			0.5	dB	

Note:

1, Even if the mTDEC<0.9dB, the OMA (min) must exceed this value.

1. If measured into type A1a.2 50um fiber in accordance with IEC 61280-1-4.

2. The receiver shall be able to tolerate, without damage, continuous exposure to a modulated optical input signal having this power level on one lane. The receiver does not have to operate correctly at this input power.

3. Average receive power, each lane (min) is informative and not the principal indicator of signal strength. A received power below this value cannot be compliant; however, a value above this does not ensure compliance.

4. Measured with conformance test signal at TP3 as per the following:

Stressed eye closure (SECq), each lane	4.5	dB
OMA of each aggressor, each lane	3	dBm

## Electrical Characteristics

Parameter	Symbol	Min.	Typ.	Max.	Units	Note
Power Consumption				4	W	
Supply Current	<i>I<sub>cc</sub></i>			1.21	A	
<b>Transmitter (each lane)</b>						
Overload Differential Voltage pk-pk	<i>TP1a</i>	900			mV	
Common Mode Voltage (V <sub>cm</sub> )	<i>TP1</i>	-350		2850	mV	1
Differential Termination Resistance Mismatch	<i>TP1</i>			10	%	at 1MHz
Differential Return Loss (SDD11)	<i>TP1</i>	See CEI-28G-VSR Equation 13-19			dB	
Common Mode to Differential conversion and Differential to Common Mode conversion (SDC11, SCD11)	<i>TP1</i>	See CEI-28G-VSR Equation 13-20			dB	2
Stressed Input Test	<i>TP1a</i>	See CEI-28G-VSR Section 13.3.11.2.1				V
<b>Receiver (each lane)</b>						
Differential Voltage, pk-pk	<i>TP4</i>			900	mV	
Common Mode Voltage (V <sub>cm</sub> )	<i>TP4</i>	-350		2850	mV	1
Common Mode Noise, RMS	<i>TP4</i>			17.5	mV	

Differential Termination Resistance Mismatch	TP4			10	%	at 1 MHz
Differential Return Loss (SDD22)	TP4	See CEI-28G-VSR Equation 13-19			dB	
Common to Mode to Differential Conversion and Differential to Common Mode conversion (SDC22, SCD22)	TP4	See CEI-28G-VSR Equation 13-21			dB	
Common Mode Return Loss (SCC22)	TP4				dB	2
Transition Time 20% to 80%	TP4	9.5			ps	
Vertical Eye Closure (VEC)	TP4				dB	
Eye Width at 10 <sup>-15</sup> probability (EW15)	TP4	0.57			UI	
Eye Height at 10 <sup>-15</sup> probability (EH15)	TP4	228			mV	

**Transceiver Block Diagram**

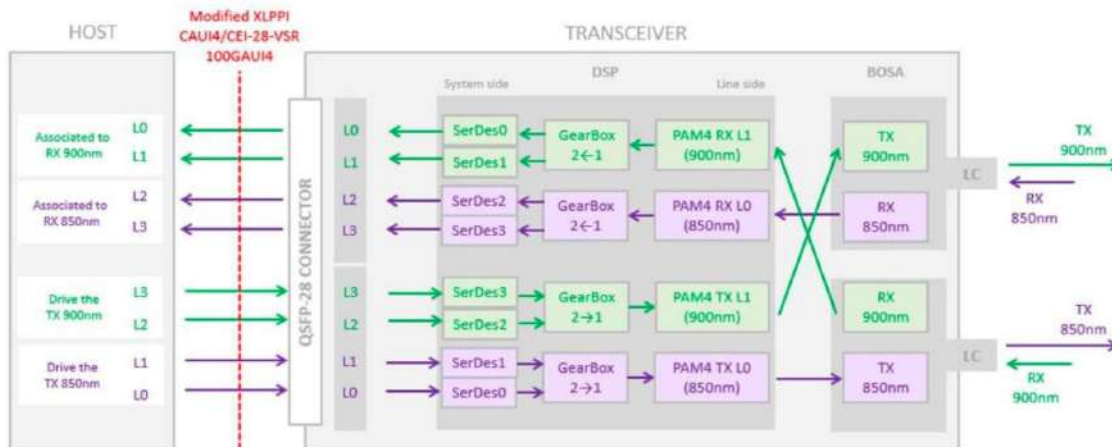

**Optical Interface Lanes and Assignment**

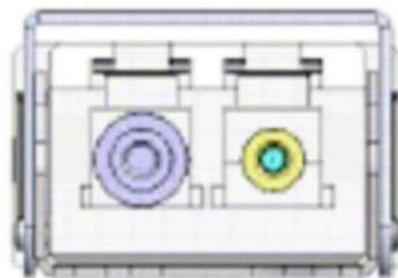

Figure 3: Outside View of the QSFP28 Module LC Receptacle

**Recommended Power Supply Filter**

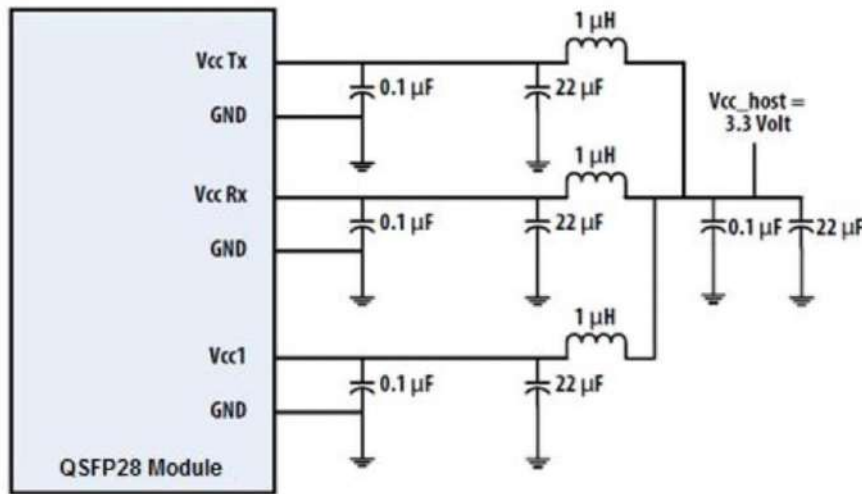

Figure 4. Recommended Power Supply Filter

**Pin Descriptions**

Pin	Logic	Symbol	Name/Description	Notes
1		GND	Ground	1
2	CML-I	Tx2n	Transmitter Inverted Data Input	
3	CML-I	Tx2p	Transmitter Non-Inverted Data Input	
4		GND	Ground	1
5	CML-I	Tx4n	Transmitter Inverted Data Input	
6	CML-I	Tx4p	Transmitter Non-Inverted Data Input	
7		GND	Ground	1
8	LVTTL-I	ModSelL	Module Select	
9	LVTTL-I	ResetL	Module Reset	
10		VccRx	+3.3V Power Supply Receiver	2
11	LVC MOS-I/O	SCL	2-wire serial interface clock	
12	LVC MOS-I/O	SDA	2-wire serial interface data	
13		GND	Ground	1
14	CML-O	Rx3p	Receiver Non-Inverted Data Output	
15	CML-O	Rx3n	Receiver Inverted Data Output	
16	GND	Ground	1B	GND
17	CML-O	Rx1p	Receiver Non-Inverted Data Output	
18	CML-O	Rx1n	Receiver Inverted Data Output	
19		GND	Ground	1
20		GND	Ground	1

21	CML-O	Rx2n	Receiver Inverted Data Output	
22	CML-O	Rx2p	Receiver Non-Inverted Data Output	
23		GND	Ground	1
24	CML-O	Rx4n	Receiver Inverted Data Output	
25	CML-O	Rx4p	Receiver Non-Inverted Data Output	
26		GND	Ground	1
27	LVTTL-O	ModPrsL	Module Present	
28	LVTTL-O	IntL	Interrupt	
29		VccTx	+3.3V Power supply transmitter	2
30		Vcc1	+3.3V Power supply	2
31	LVTTL-I	LPMODE	Low Power Mode	
32		GND	Ground	1
33	CML-I	Tx3p	Transmitter Non-Inverted Data Input	
34	CML-I	Tx3n	Transmitter Inverted Data Input	
35		GND	Ground	1
36	CML-I	Tx1p	Transmitter Non-Inverted Data Input	
37	CML-I	Tx1n	Transmitter Inverted Data Input	
38		GND	Ground	1

**Notes:**

- GND is the symbol for signal and supply (power) common for QSFP28 modules. All are common within the QSFP28 module and all module voltages are referenced to this potential unless otherwise noted. Connect these directly to the host board signal common ground plane.
- VccRx, Vcc1 and VccTx are the receiver and transmitter power suppliers and shall be applied concurrently. Recommended host board power supply filtering is shown in Figure 4 below. Vcc Rx, Vcc1 and Vcc Tx maybe internally connected within the QSFP28 transceiver module in any combination. The connector pins are each rated for a maximum current of 1000mA

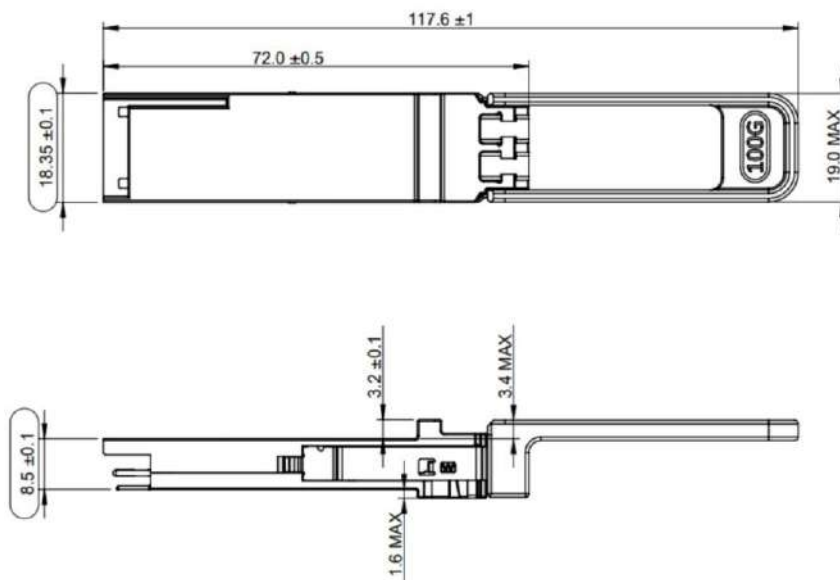
**Dimensions**

**Optical Receptacle Cleaning Recommendations:**

All fiber stubs inside the receptacle portions were cleaned before shipment. In the event of contamination of the optical ports, the recommended cleaning process is the use of forced nitrogen. If contamination is thought to have remained, the optical ports can be cleaned using a NTT international Cletop® stick type and HFE7100 cleaning fluid. Before the mating of patch-cord, the fiber end should be cleaned up by using Cletop® cleaning cassette.

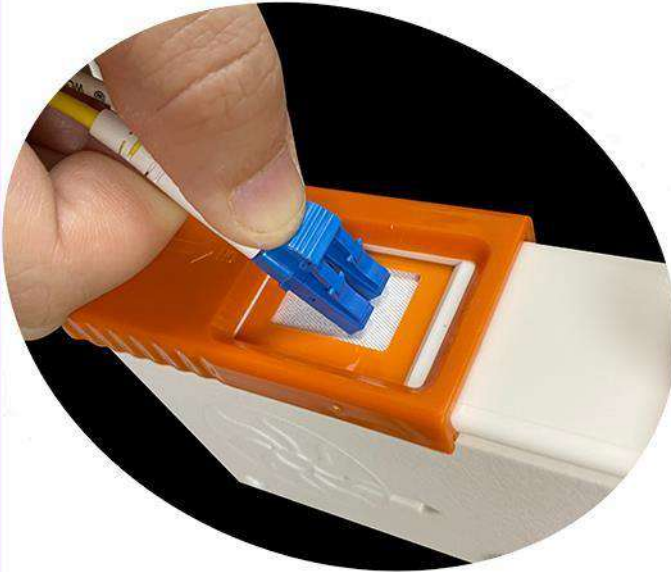
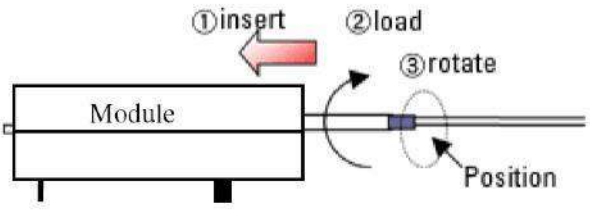
<p><b>Cleaning of patch-cord</b></p> 	<p><b>Cleaning of fiber stub</b></p>  <ol style="list-style-type: none"> <li><b>1. Insert</b> Ensure that stick is held straight when inserting into sleeve.</li> <li><b>2. Load</b> Apply sufficient pressure (approx 600-700g) to ensure ferrule a little depressed in sleeve.</li> <li><b>3. Rotate</b> Rotate stick clockwise 4-5 times, while ensuring direct contact with ferrule end-face is maintained.</li> </ol> <p><i>Notice: Number of possible wipes: Maintenance (repair) ~1 use / piece Equipment construction: 4 uses / piece (max.)</i></p>
---	--

Note: The pictures were extracted from NTT-ME website. And the Cletop® is a trademark registered by NTT-ME

**Ordering information:**

Model Number	Part Number	Voltage	Temperature
AQSFP28-100G-SX4	OPCW-WX1-85-CB	3.3V	10°C to 70 °C

Note: All information contained in this document is subject to change without notice.

**Copyright @ Alpha Bridge Technologies Private Limited**

This document is ABTPL Public Information. ABTPL reserves the right to alter, update, and otherwise change the information contained in the document from time to time.  
www.alphabridge.tech