

Features

- Compliant with QSFP28 Standard: SFF-8661 Revision 1.9, SFF-8636Revision 2.10a
- Compliant to IEEE 802.3-2018 100GBASE-LR4 and OTU4 411-9D1F
- High speed I/O electrical interface (CAUI-4) compliant with IEEE802.3-2018
- Single 3.3V Supply Voltage
- LAN WDM EML laser and PIN Receiver Array
- QSFP28 MSA package with duplex LC connector
- Two Wire Serial Interface with Digital Diagnostic Monitoring
- Maximum power consumption 3.5W
- LC duplex connector
- Complies with EU Directive 2011/65/EU (RoHS compliant)
- Class 1 Laser
- Commercial case temperature range of 0°C to 70°C

Description

This 100G LR4 product is designed for 10km optical communication applications, and it is compliant to IEEE802.3ba for 100GE Ethernet. This module contains 4-lane optical transmitter, 4-lane optical receiver and module management block including 2 wire serial interface. The optical signals are multiplexed to a single-mode fiber through an industry standard LC connector.

Absolute Maximum Ratings

Parameter	Symbol	Min.	Typ.	Max.	Units	Note
Storage Temperature	T_S	-40		85	°C	
Supply Voltage	V_{CC}	-0.3		3.6	V	
Relative Humidity	RH	5		95	%	1
Data Input Voltage-Differential	$IVDIP-VDINI$			1.0	V	
Control Input Voltage	V_I	-0.3		$V_{CC}+0.5$	V	
Control Output Current	I_O	-20		20	mA	

Note:

1. non-condensing.

Recommended Operating Conditions

Parameter	Symbol	Min.	Typ.	Max.	Units	Note
Supply Voltage	V_{CC}	3.135	3.3	3.465	V	
Case Temperature	T_{op}	0		70	°C	
Instantaneous Peak Current at Hot Plug	I_{CC_IP}			1400	mA	
Sustained Peak Current at Hot Plug	I_{CC_SP}			1155	mA	
Maximum Power Dissipation	P_D			3.5	W	
Maximum Power Dissipation. Low Power Mode	P_{DLP}			1.5	W	
Aggregate Bit Rate	ABR		103.125	111.8	Gb/s	
Data Rate Per Lane	DRL		25.78	27.95	Gb/s	
Control Input Voltage-High	V_{IH}	$V_{CC}+0.7$		$V_{CC}+0.3$	V	

Control Input Voltage-Low	V_{IL}	-0.3		$V_{cc}+0.3$	V	
Two Wire Serial Interface Clock Rate				400	kHz	
Module Power Supply Noise Tolerance 10Hz-10MHz (peak to peak)				66	mVpp	
Rx Differential Data Output Load			100		ohms	
Operating Distance			2	10	km	

Diagnostics Monitoring

Performance Item	Range	Monitor Error	Notes
Module Temperature	0~70	$\pm 3^{\circ}\text{C}$	
Module Voltage	0 to V_{cc}	$\pm 3\%$	
Tx Bias Current ,each Lane	0 to 100	$\pm 10\%$	
Tx Output Power ,each Lane	-4.3 to 4.5	$\pm 3\text{dB}$	
Rx Power, each Lane	-10.6 to 4.5	$\pm 3\text{dB}$	

Optical Characteristics

Parameter	Symbol	Min.	Typ.	Max.	Units	Note
Transmit Wavelengths		1294.53	1295.56	1296.59	nm	
		1299.02	1300.05	1301.09	nm	
		1303.54	1304.58	1305.63	nm	
		1308.09	1309.14	1310.19	nm	
Transmitter						
Side-mode Suppression Ratio	SMSR	30			dB	
Total Average Launch Power				10.5	dBm	
Average launch power, each Lane	P_{AVG}	-4.3	4.5	-4.3	dBm	
Optical Modulation Amplitude (OMA), each Lane	P_{OMA}	-1.3	4.5	-1.3	dBm	
Transmitter and Dispersion Penalty (TDP), each lane				2.2	dB	
Extinction Ratio	ER	4			dB	
Launch Power in OMA minus TDP, each Lane	$OMA-TDP$	-2.3			dBm	
Difference in Launch Power Between Any Two Lanes (OMA)	DT_OMA		5		dB	
Transmitter and Dispersion Penalty, each Lane	TDP		2.2		dB	
Optical Return Loss Penalty, each Lane	$ORLT$		20		dB	
Transmitter Eye Mask Definition {X1, X2, X3, Y1, Y2, Y3}		{0.25, 0.4, 0.45, 0.25, 0.28, 0.4}				
RIN20OMA	RIN		-130		dB/Hz	
Receiver						
Receiver Sensitivity (OMA), each Lane				-8.6	dBm	

Stressed Receiver Sensitivity in OMA, each Lane				-6.8	dBm	
Damage Threshold for Receiver	<i>Pin, Damage</i>	5.5			dBm	
Average Receiver Power, each Lane		-10.6		4.5	dBm	
Receiver Power in OMA, each Lane, Overload	<i>OMA</i>			.5	dBm	
Difference in Receive Power Between Any Two Lanes (OMA)	<i>DR_OMA</i>			5.5	dB	
Reflectance of Optical Network Element				-26	dB	
Receiver 3dB Electrical Upper Cut-off Frequency, each Lane	<i>F_C</i>			31	GHz	
Receiver Reflectance	<i>RXR</i>			-26	dB	
Vertical Eye Closure Penalty, each Lane		1.8			dB	
Stressed Eye J2 Jitter, each Lane		0.3			UI	
Stressed Eye J9 Jitter, each Lane		0.47			UI	

Notes: Measure with a PRBS2³¹-1 test pattern @25.78125Gbps, BER≤10⁻¹²

Electrical Characteristics

Parameter	Symbol	Min.	Typ.	Max.	Units	notes
Power Consumption				3.5	W	
Transmitter (each Lane)						
Differential Data Input Amplitude	<i>Vin, pp</i>	95	900		mV	At 1 Hz
Differential Termination Mismatch			10		%	
	<i>VIL</i>	-0.3	0.8		V	
LPMODE, Reset and ModSelL	<i>VIH</i>	2	Vcc+0.3		V	
Differential output voltage swing	<i>Vout, pp</i>		900		mVpp	
Differential Termination Resistance Mismatch			10		%	At 1 MHz
Transition Time (20% ~ 80%)	<i>Trise/Tfall</i>	12			ps	
ModPrsL, and IntL	<i>VOL</i>	0	0.4		V	
	<i>VOH</i>	Vcc-0.5	Vcc+0.3		V	

Block Diagram of Transceiver

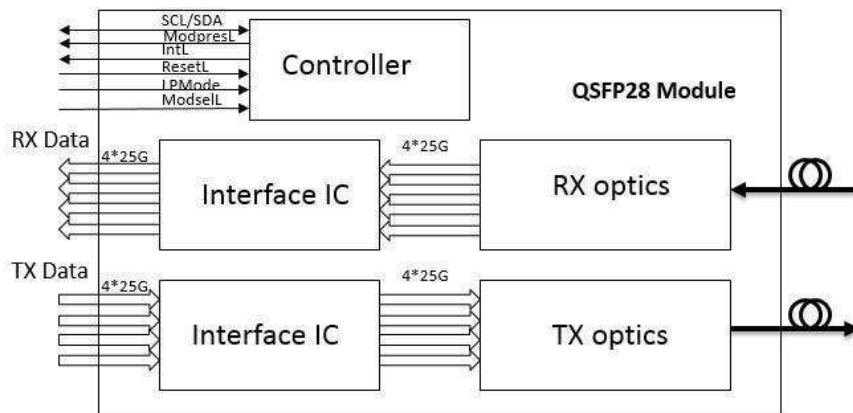

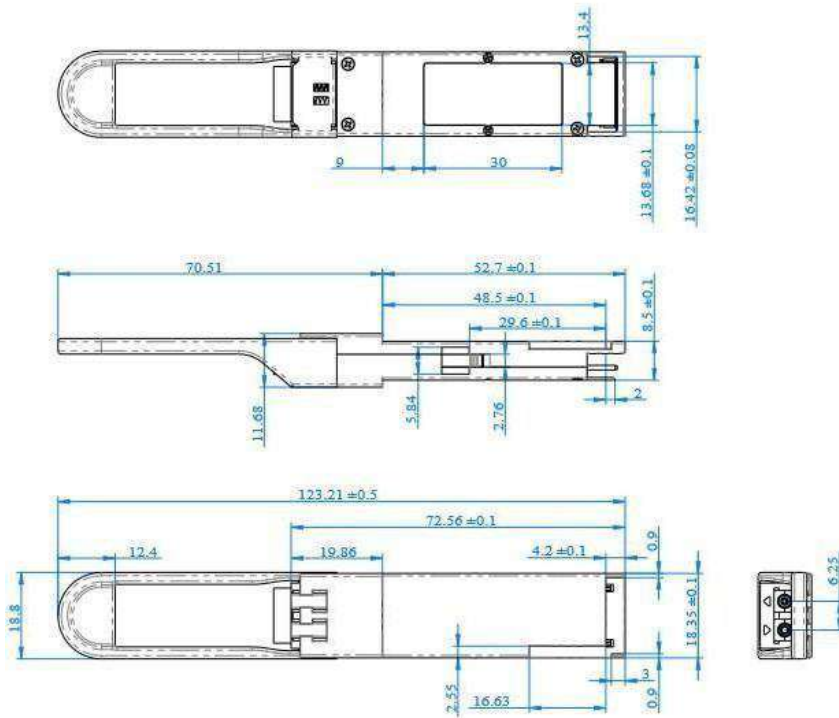
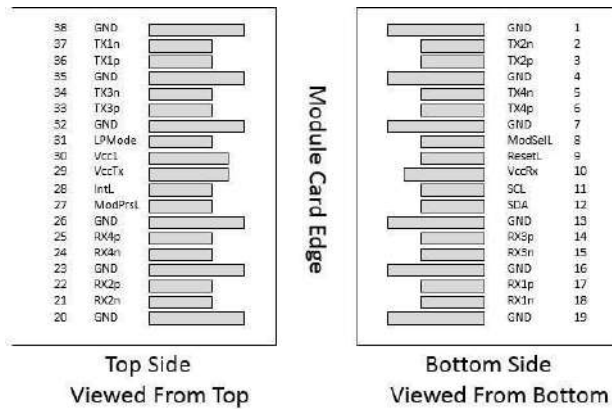
Pin Assignment and Description

Pin Descriptions

Pin	Symbol	Name/Description	Notes
1	GND	Ground	1
2	Tx2n	Transmitter Inverted Data Input	
3	Tx2p	Transmitter Non-Inverted Data Input	
4	GND	Ground	1
5	Tx4n	Transmitter Inverted Data Input	
6	Tx4p	Transmitter Non-Inverted Data Input	
7	GND	Ground	1
8	ModSelL	Module Select	
9	ResetL	Module Reset	

10	Vcc Rx	+3.3V Power Supply Receiver	2
11	SCL	2-wire serial interface clock	
12	SDA	2-wire serial interface data	
13	GND	Ground	1
14	Rx3p	Receiver Non-Inverted Data Output	
15	Rx3n	Receiver Inverted Data Output	
16	GND	Ground	1
17	Rx1p	Receiver Non-Inverted Data Output	
18	Rx1n	Receiver Inverted Data Output	
19	GND	Ground	1
20	GND	Ground	1
21	Rx2n	Receiver Inverted Data Output	
22	Rx2p	Receiver Non-Inverted Data Output	
23	GND	Ground	1
24	Rx4n	Receiver Inverted Data Output	
25	Rx4p	Receiver Non-Inverted Data Output	
26	GND	Ground	1
27	ModPrsL	Module Present	
28	IntL	Interrupt	
29	Vcc Tx	+3.3V Power supply transmitter	
30	Vcc1	+3.3V Power supply	
31	LPMode	Low Power Mode	
32	GND	Ground	
33	Tx3p	Transmitter Non-Inverted Data Input	
34	Tx3n	Transmitter Inverted Data Input	
35	GND	Ground	
36	Tx1p	Transmitter Non-Inverted Data Input	
37	Tx1n	Transmitter Inverted Data Input	
38	GND	Ground	

Notes:

1. GND is the symbol for signal and supply (power) common for the module. All any common within the module and all module voltages are referenced to this potential unless otherwise noted. Connect these directly to the host board signal-common ground plane.
2. VccRx, Vcc1 and VccTx are applied concurrently and may be internally connected within the module in any combination. Vcc contacts in SFF-8672 each have a steady state current rating of 1A.

Optical Receptacle Cleaning Recommendations:

All fiber stubs inside the receptacle portions were cleaned before shipment. In the event of contamination of the optical ports, the recommended cleaning process is the use of forced nitrogen. If contamination is thought to have remained, the optical ports can be cleaned using a NTT international Cletop® stick type and HFE7100 cleaning fluid. Before the mating of patch-cord, the fiber end should be cleaned up by using Cletop® cleaning cassette.

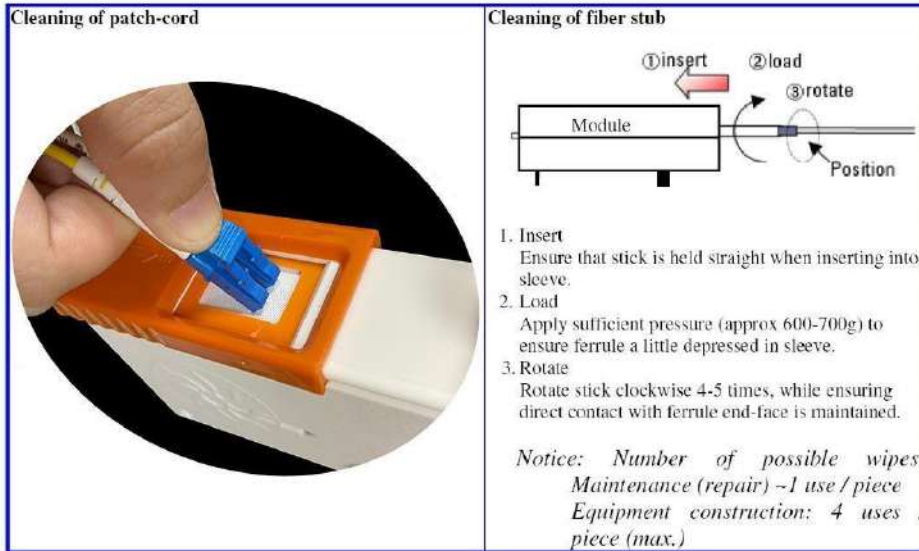

Note: The pictures were extracted from NTT-ME website. And the Cletop® is a trademark registered by NTT-ME

Ordering Information

Model Number	Part Number	Voltage	Temperature
AQSFP28-100G-LR4-CY	OPCW-S10-13-CY	3.3V	0°C to 70 °C

Note: All information contained in this document is subject to change without notice.

