

**Alpha Bridge  
AQSFP28-100G-DR1  
Datasheet**



## Features

- QSFP28 MSA compliant
- Supports 53.125Gbaud
- IEEE802.3cd 100GBASE-DR Specification compliant
- Up to 500m transmission on single mode fiber (SMF) with FEC
- Operating case temperature: 0 to 70°C
- 4x25G electrical interface (OIF CEI-28G-VSR)
- Maximum power consumption 4W
- LC duplex connector
- RoHS compliant

## Applications

- Data Center Interconnect
- 100G Ethernet
- Enterprise networking

## Description

This product is a transceiver module designed for 500m optical communication applications. The module incorporates one channel optical signal, on 1310nm center wavelength, operating at 50Gbaud data rate. The transmitter path incorporates an EML Driver and a cooled EML together. On the receiver path, the input optical signal is coupled to a Pin photodiode detector. A DSP based gearbox is used to convert 4x25Gbps NRZ signals to 1x50Gbaud PAM4 signal. Also a 4-channel retimer and FEC block are integrated in this DSP. The electrical interface is compliant with IEEE 802.3cd and QSFP28 MSA in the transmitting and receiving directions, and optical interface is compliant with IEEE 802.3cd and 100G Lambda MSA with Duplex LC connector. The module has a maximum power consumption of 3.5W.

The product is designed with form factor, optical/electrical connection and digital diagnostic interface according to the QSFP28 Multi-Source Agreement (MSA). It has been designed to meet the harshest external operating conditions including temperature, humidity and EMI interference.

## Absolute Maximum Ratings

Parameter	Symbol	Min	Max	Unit	Note
Storage Temperature	Ts	-40	85	°C	
Operating Case Temperature	TOP	0	70	°C	
Supply Voltage	Vcc	-0.5	3.6	V	
Relative Humidity (non-condensation)	RH	0	85	%	
Damage Threshold, each Lane	TH <sub>d</sub>	6.5		dBm	

## Recommended Operating Conditions

Parameter	Symbol	Min	Typical	Max	Unit	Notes
Operating Case Temperature	TOP	0		70	degC	
Power Supply Voltage	VCC	3.135	3.3	3.465	V	
Electrical Data Rate, each Lane (NRZ)			25.78125		Gb/s	
Optical Data Rate (PAM4)			53.125		GBd	
Data Rate Accuracy		-100		100	ppm	
Pre-FEC Bit Error Ratio				2.4x10 <sup>-4</sup>		
Post-FEC Bit Error Ratio				1x10 <sup>-12</sup>		1
Control Input Voltage High		2		Vcc	V	
Control Input Voltage Low		0		0.8	V	
Link Distance with G.652	D	0.002		500	m	2

Notes:

1. FEC feature is embedded in the module.
2. FEC required to be turned on to support maximum transaction distance.

**Diagnostics Monitoring**

Parameter	Symbol	Accuracy	Unit	Notes
Temperature monitor absolute error	DMI_Temp	± 3	°C	Over operating temperature range
Supply voltage monitor absolute error	DMI_VCC	± 0.1	V	Over full operating range
Channel RX power monitor absolute error	DMI_RX_Ch	± 2	dB	1
Channel Bias current monitor	DMI_Ibias_Ch	± 10%	mA	
Channel TX power monitor absolute error	DMI_TX_Ch	± 2	dB	1

- Notes:
- Due to measurement accuracy of different single mode fibers, there could be an additional +/- 1 dB fluctuation, or a +/- 3 dB total accuracy.

**Transmitter Electro-optical Characteristics (each Lane)**

Parameter	Test Point	Min	Typical	Max	Unit	Notes
Power Consumption				4.5	W	
Supply Current	Icc			1.36	A	
Overload Differential Voltage pk-pk	TP1a	900			mV	
Common Mode Voltage (Vcm)	TP1	-350		2850	mV	1
Differential Termination Resistance Mismatch	TP1			10	%	At 1MHz
Differential Return Loss (SDD11)	TP1	See CEI28G-VSR Equation 13-19			dB	
Common Mode to Differential conversion and Differential to Common Mode conversion (SDC11, SCD11)	TP1	See CEI28G-VSR Equation 13-20			dB	
Stressed Input Test	TP1a	See CEI28G-VSR Section 13.3.11.2.1				
Center Wavelength	λt	1304.5		1317.5	nm	
Side Mode Suppression Ratio	SMSR	30			dB	
Average Launch Power	PAVG	-2.4		4	dBm	2
Outer Optical Modulation Amplitude (OMAouter)	POMA	-0.3		4.2	dBm	3
Launch Power in OMAouter minus Transmitter and Dispersion Eye Closure (TDECQ)		1.3			dBm	
Transmitter and Dispersion Eye Closure for PAM4 (TDECQ)	TDECQ			2.5	dB	
Extinction Ratio	ER	5			dB	
RIN <sub>20OMA</sub>	RIN			-136	dB/Hz	
Optical Return Loss Tolerance	TOL			15.5	dB	
Transmitter Reflectance	R <sub>T</sub>			-26	dB	
Average Launch Power OFF Transmitter	Poff			-15	dBm	

- Notes:
- Vcm is generated by the host. Specification includes effects of ground offset voltage.
  - Average launch power, each lane min is informative and not the principal indicator of signal strength. A transmitter with launch power below this value cannot be compliant; however, a value above this does not ensure compliance.
  - Even if the TDECQ < 1.4dB for an extinction ratio of ≥ 4.5dB or TDECQ < 1.3dB for an extinction ratio of < 4.5dB, the OMAouter (min) must exceed the minimum value specified here.

**Receiver Electro-optical Characteristics (each Lane)**

Parameter	Symbol	Min	Typical	Max	Unit	Notes
Differential Voltage, pk-pk	TP4			900	mV	
Common Mode Voltage (Vcm)	TP4	-350		2850	mV	1
Common Mode Noise, RMS	TP4			17.5	mV	
Differential Termination Resistance Mismatch	TP4			10	%	At 1MHz
Differential Return Loss (SDD22)	TP4	See CEI- 28G-VSR Equation 13-19			dB	
Common Mode to Differential conversion and Differential to Common Mode conversion (SDC22, SCD22)	TP4	See CEI- 28G-VSR Equation 13-21			dB	
Common Mode Return Loss (SCC22)	TP4			-2	dB	2
Transition Time, 20 to 80%	TP4	9.5			ps	
Vertical Eye Closure (VEC)	TP4			5.5	dB	
Eye Width at 10-15 probability (EW15)	TP4	0.57			UI	
Eye Height at 10-15 probability (EH15)	TP4	228			mV	
Center Wavelength	$\lambda_r$	1304.5		1317.5	nm	
Damage Threshold	THd	6.5			dBm	3
Average Receive Power		-5.4		4	dBm	
Receive Power (OMAouter)				4.2	dBm	
Receiver Sensitivity (OMAouter)	SEN			-4.4	dBm	for BER=2.4x10 <sup>-4</sup>
Stressed Receiver Sensitivity (OMAouter)	SRS			-1.9	dBm	4
Receiver Reflectance	RR			-26	dB	
LOS Assert	LOSA	-30			dBm	
LOS Deassert	LOSD			-15	dBm	
LOS Hysteresis	LOSH	0.5			dB	
<b>Conditions of Stress Receiver Sensitivity Test (Note 5)</b>						
Stressed Eye Closure for PAM4 (SECQ)			2.5		dB	

Notes:

- Vcm is generated by the host. Specification includes effects of ground offset voltage.
- From 250MHz to 30GHz.
- The receiver shall be able to tolerate, without damage, continuous exposure to a modulated optical input signal having this power level on one lane. The receiver does not have to operate correctly at this input power.
- Measured with conformance test signal for BER = 2.4x10<sup>-4</sup>. A compliant receiver shall have stressed receiver sensitivity (OMAouter) values below the mask of Figure 4, for SECQ values between 0.9 and 3.4 dB.
- Stressed eye closure definition is test condition for measuring stressed receiver sensitivity. It is not a characteristic of the receiver.

**Block Diagram of Transceiver**

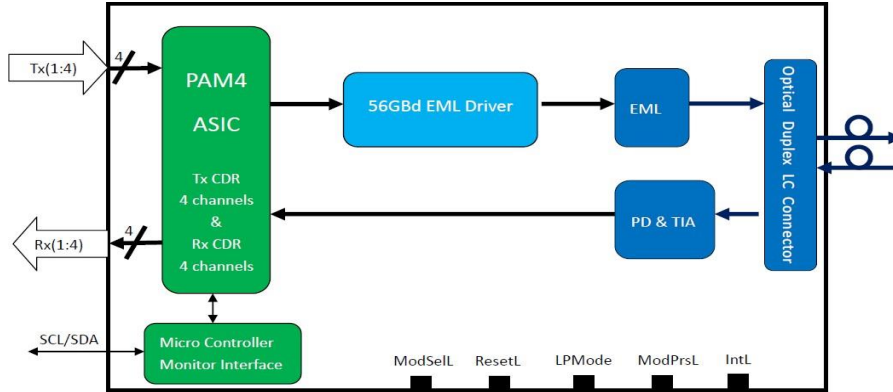

This product converts the 4-channel of 100Gbps aggregated NRZ electrical input data into one channel of 50Gbaud PAM4 optical signal (light) on 1310nm center wavelength through a DSP based gearbox, by a driven cooled Electro-absorption Modulated DFB Laser (EML). The light propagates out of the transmitter into an SMF fiber. The receiver module accepts the 50Gbaud PAM4 optical signal input, and converts it into a 50Gbaud PAM4 electrical signal via a linear amplifier. And then convert the 50Gbaud PAM4 signal into 4 channels of 25Gbps NRZ signals. Above figure shows the functional block diagram of this product.

A single +3.3V power supply is required to power up this product. Both power supply pins VccTx and VccRx are internally connected and should be applied concurrently. As per MSA specifications the module offers seven low speed hardware control pins (including the 2-wire serial interface): ModSelL, SCL, SDA, ResetL, LPMODE, ModPrsL and IntL.

Module Select (ModSelL) is an input pin. When held low by the host, this product responds to 2- wire serial communication commands. The ModSelL allows the use of this product on a single 2- wire interface bus – individual ModSelL lines must be used.

Serial Clock (SCL) and Serial Data (SDA) are required for the 2-wire serial bus communication interface and enable the host to access the memory map.

The ResetL pin enables a complete reset, returning the settings to their default state, when a low level on the ResetL pin is held for longer than the minimum pulse length. During the execution of a reset the host shall disregard all status bits until it indicates a completion of the reset interrupt. The product indicates this by posting an IntL (Interrupt) signal with the Data\_Not\_Ready bit negated in the memory map. Note that on power up (including hot insertion) the module should post this completion of reset interrupt without requiring a reset.

Low Power Mode (LPMODE) pin is used to set the maximum power consumption for the product in order to protect hosts that are not capable of cooling higher power modules, should such modules be accidentally inserted.

Module Present (ModPrsL) is a signal local to the host board which, in the absence of a product, is normally pulled up to the host Vcc. When the product is inserted into the connector, it completes the path to ground through a resistor on the host board and asserts the signal. ModPrsL then indicates its present by setting ModPrsL to a “Low” state.

Interrupt (IntL) is an output pin. “Low” indicates a possible operational fault or a status critical to the host system. The host identifies the source of the interrupt using the 2-wire serial interface. The IntL pin is an open collector output and must be pulled to the Host Vcc voltage on the Host board.

**Pin Assignment**

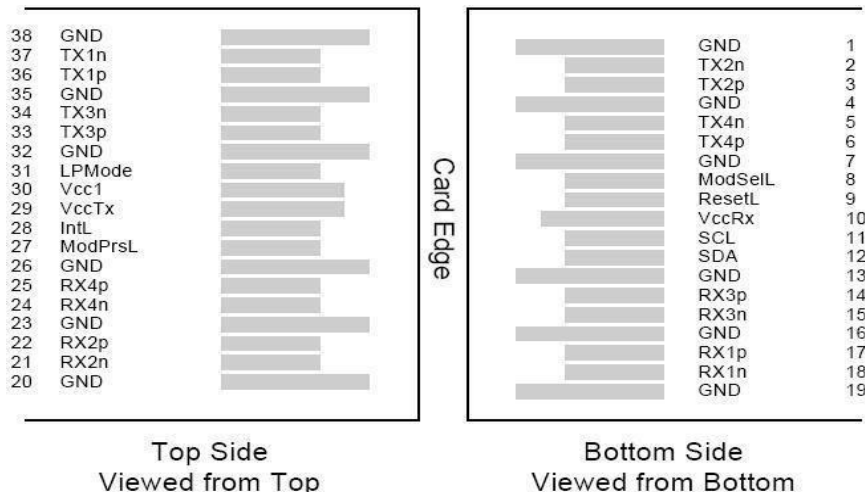

**Pin Description**

PIN	Logic	Symbol	Name/Description	Note
1		GND	Ground	1
2	CML-I	Tx2n	Transmitter Inverted Data Input	
3	CML-I	Tx2p	Transmitter Non-Inverted Data output	
4		GND	Ground	1
5	CML-I	Tx4n	Transmitter inverted Data Input	
6	CML-I	Tx4p	Transmitter Non-Inverted Data output	
7		GND	Ground	1
8	LVTLL-I	ModSelL	Module Select	
9	LVTLL-I	ResetL	Module Reset	
10		VccRx	+3.3V Power Supply Receiver	2
11	LVC MOS-I/O	SCL	2-Wire Serial Interface Clock	
12	LVC MOS-I/O	SDA	2-Wire Serial Interface Data	
13		GNC	Ground	
14	CML-O	Rx3p	Receiver Non-Inverted Data output	
15	CML-O	Rx3n	Receiver Inverted Data output	
16		GND	Ground	1
17	CML-O	Rx1p	Receiver Non-Inverted Data Output	
18	CML-O	Rx1n	Receiver Inverted Data Output	
19		GND	Ground	1
20		GND	Ground	1
21	CML-O	Rx2n	Receiver Inverted Data output	
22	CML-O	Rx2p	Receiver Non-Inverted Data output	
23		GND	Ground	1
24	CML-O	Rx4n	Receiver Inverted Data output	1
25	CML-O	Rx4p	Receiver Non-Inverted Data output	
26		GND	Ground	1
27	LVTTL-O	ModPrsL	Module Present	
28	LVTTL-O	IntL	Interrupt	
29		VccTx	+3.3V Power Supply transmitter	2
30		Vcc1	+3.3V Power Supply	2
31	LVTTL-I	LPMODE	Low Power Mode	
32		GND	Ground	1
33	CML-I	Tx3p	Transmitter Non-Inverted Data Input	
34	CML-I	Tx3n	Transmitter Inverted Data Output	
35		GND	Ground	1
36	CML-I	Tx1p	Transmitter Non-Inverted Data Input	
37	CML-I	Tx1n	Transmitter Inverted Data Output	
38		GND	Ground	1

**Notes:**

1. GND is the symbol for signal and supply (power) common for QSFP28 modules. All are common within the QSFP28 module and all module voltages are referenced to this potential unless otherwise noted. Connect these directly to the host board signal common ground plane.
2. VccRx, Vcc1 and VccTx are the receiving and transmission power suppliers and shall be applied concurrently. Recommended host board power supply filtering is shown below. Vcc Rx, Vcc1 and Vcc Tx may be internally connected within the QSFP28 transceiver module in any combination.

**Recommended Power Supply Filter**

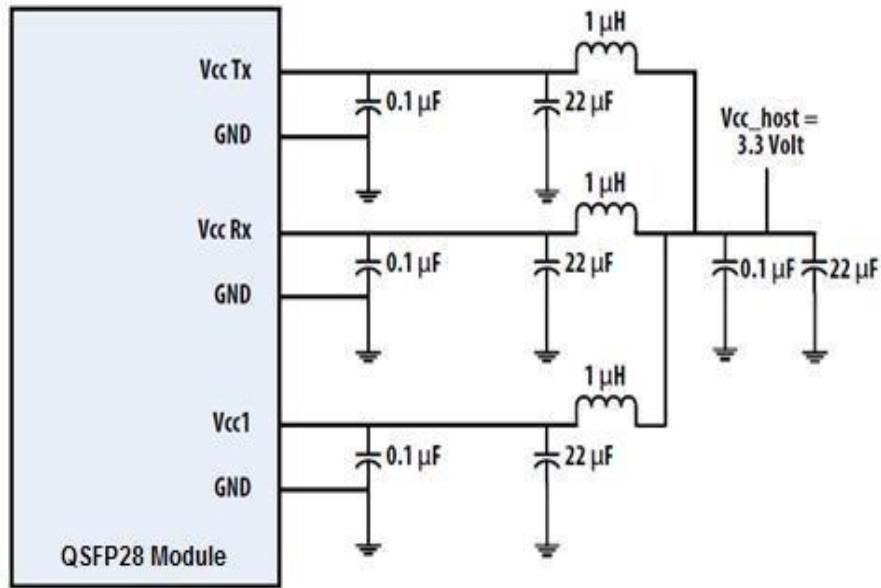

**Dimensions**

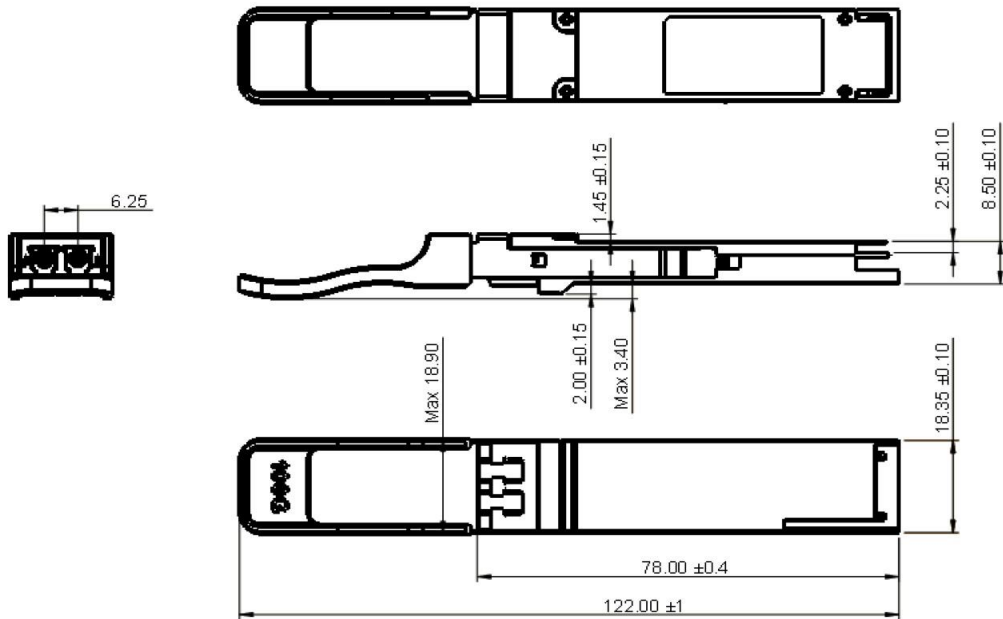

**Optical Receptacle Cleaning Recommendations**

All fiber stubs inside the receptacle portions were cleaned before shipment. In the event of contamination of the optical ports, the recommended cleaning process is the use of forced nitrogen. If contamination is thought to have remained, the optical ports can be cleaned using a NTT international Cletop<sup>®</sup> stick type and HFE7100 cleaning fluid. Before the mating of patch-cord, the fiber end should be cleaned up by using Cletop<sup>®</sup> cleaning cassette.

**Cleaning of patch-cord**



**Cleaning of fiber stub**

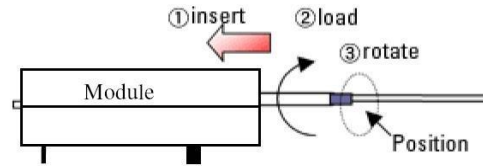

1. Insert  
Ensure that stick is held straight when inserting into sleeve.
2. Load  
Apply sufficient pressure (approx 600-700g) to ensure ferrule a little depressed in sleeve.
3. Rotate  
Rotate stick clockwise 4-5 times, while ensuring direct contact with ferrule end-face is maintained.

*Notice: Number of possible wipes:  
Maintenance (repair) ~1 use / piece  
Equipment construction: 4 uses / piece (max.)*

Note: The pictures were extracted from NTT-ME website. And the Cletop<sup>®</sup> is a trademark registered by NTT-ME

**Ordering Information**

Model Number	Part Number	Voltage	Temperature
AQSFP28-100G-DR1	OPCW-SX5-13-CB1	3.3V	0°C to 70 °C