

Alpha Bridge AQSFP-T-1-A Datasheet



Features

- Compliant with QSFP+ SFF8436
- Support IEEE P802.3ba (Ethernet)
- Support 8GFC & 10GFC (Fiber Channel)
- Support for multi-gigabit data rates : 1.0Gbps ~ 10.3125Gbps (per channel)
- Maximum throughput: 82.5Gbps(Tx and Rx)
- Copper link length up to 10m (active limiting)
- High-Density QSFP 38-PIN Connector
- Low crosstalk
- I2C based two-wire serial interface for easy control and monitoring
- Management interface acc. SFF-8436
- Power consumption: 1.5W
- RoHS Compliant

Absolute Maximum Ratings

Parameter	Symbol	Min.	Max.	Units	Note
Storage Temperature	T_S	-40	80	°C	
Power Supply Voltage	V_{CC}	3.14	3.47	V	

Recommended Operating Conditions

Parameter	Symbol	Min.	Max.	Units	Note
Operating Case Temperature	T_c	0	70	°C	
Power Supply Voltage	V_{CC}	3.14	3.47	V	
Power Dissipation	PD		0.5	W	

Cable Mechanical Specifications

Parameter	Symbol	Min	Type	Max	Units	Notes
Wire Gauge	30AWG	-	24 AWG	Wire Gauge		
Cable Impedance	Z	90	100	110	Ohm	

Pin Assignment

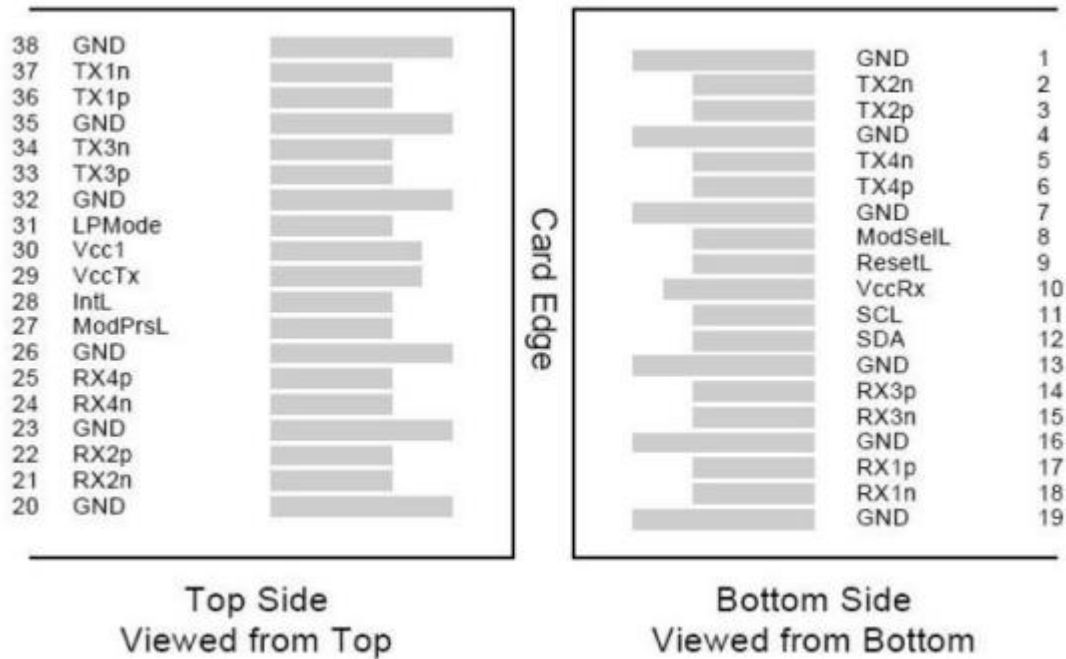

Pin Description

Pin	Logic	Symbol	Description	Notes
1		GND	Ground	1
2	CML-I	Tx2n	Transmitter Inverted Data Input	
3	CML-I	Tx2p	Transmitter Non-inverted Data Input	
4		GND	Ground	1
5	CML-I	Tx4n	Transmitter Inverted Data Input	
6	CML-I	Tx4p	Transmitter Non-inverted Data Input	
7		GND	Ground	1
8	LVTTTL-I	ModSelL	Module Select	
9	LVTTTL-I	ResetL	Module Reset	
10		VccRx	+3.3V Power Supply Receiver	2
11	LVCMOS-I/O	SCL	2-Wire Serial Interface Clock	
12	LVCMOS-I/O	SDA	2-Wire Serial Interface Data	
13		GND	Ground	
14	CML-O	Rx3p	Receiver Non-Inverted Data Output	
15	CML-O	Rx3n	Receiver Inverted Data Output	
16		GND	Ground	1
17	CML-O	Rx1p	Receiver Non-Inverted Data Output	
18	CML-O	Rx1n	Receiver Inverted Data Output	
19		GND	Ground	1
20		GND	Ground	1

21	CML-O	Rx2n	Receiver Inverted Data Output	
22	CML-O	Rx2p	Receiver Non-Inverted Data Output	
23		GND	Ground	1
24	CML-O	Rx4n	Receiver Inverted Data Output	
25	CML-O	Rx4p	Receiver Non-Inverted Data Output	
26		GND	Ground	1
27	LVTTTL-O	ModPrsL	Module Present	
28	LVTTTL-O	IntL	Interrupt	
29		VccTx	+3.3V Power Supply Transmitter	2
30		Vcc1	+3.3V Power Supply	2
31	LVTTTL-1	LPMODE	Low Power Mode	
32		GND	Ground	1
33	CML-I	Tx3p	Transmitter Non-Inverted Data Input	
34	CML-I	Tx3n	Transmitter Inverted Data Input	
35		GND	Ground	1
36	CML-I	Tx1p	Transmitter Non-Inverted Data Input	
37	CML-I	Tx1n	Transmitter Inverted Data Input	
38		GND	Ground	1

- Note:
- GND is the symbol for signal and supply (power) common for QSFP28 modules. All are common within the QSFP28 module and all module voltages are referenced to this potential unless otherwise noted. Connect these directly to the host board signal common ground plane.
 - VccRx, Vcc1 and VccTx are the receiving and transmission power suppliers and shall be applied concurrently. Recommended host board power supply filtering is shown in Figure 3 below. Vcc Rx, Vcc1 and Vcc Tx may be internally connected within the QSFP28 transceiver module in any combination. The connector pins are each rated for a maximum current of 1000mA.

Dimensions

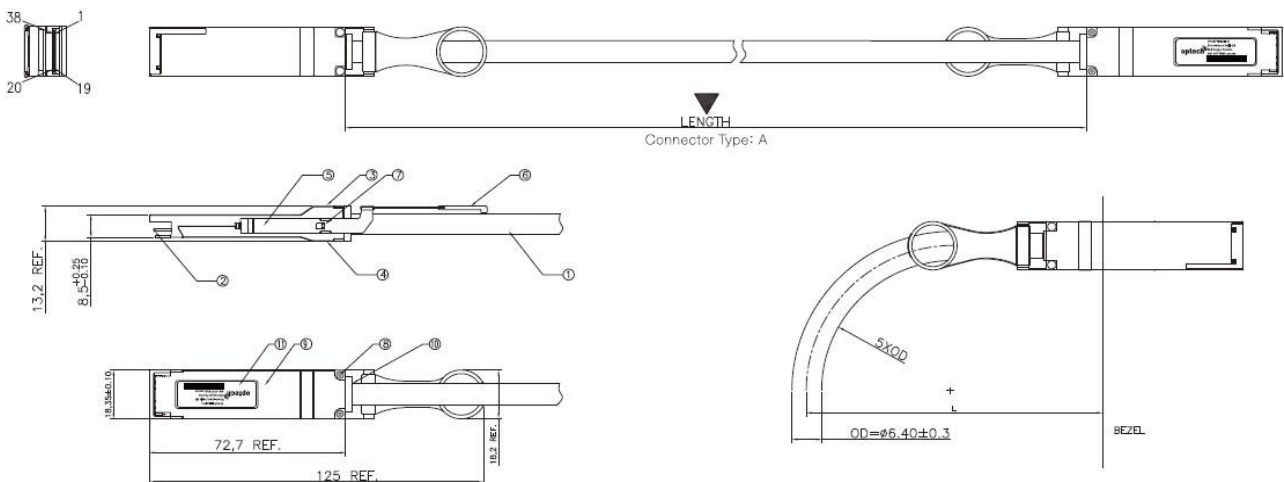

Ordering Information

<i>Part Number</i>	<i>Model Number</i>	<i>Length (M)</i>	<i>AWG</i>	<i>Voltage</i>	<i>Temperature</i>
AQSFP-T-01-A	Twinax Copper	1	30	3.3V	0 °C to 70 °C

Note: All information contained in this document is subject to change without notice.