

**Alpha Bridge SFP
AQSFP-DD-ZR+ Datasheet**



AQSFP-DD-ZR+ Datasheet



• Features

- Support Flex-grid channel spacing DWDM in C-band
- Support Client-side Interfaces: 1x400GAUI-8/4x100GAUI-2
- Support Line-side DP-16QAM with oFEC (OpenZR+)
- Standard QSFP-DD Type 2 form factor
- 76pin QSFP-DD MSA compliant connector
- Compliant to CMIS 5.0
- Compliant to OIF Implementation Agreement for Coherent CMIS, Rev 01.1
- OpenZR+ Specifications, version 1.0, 4 September 2020
- RoHS compliant

Description

This 400G OpenZR+ QSFP-DD DCO modules based on DP-16QAM supporting extended C-band, polarization diversity coherent detection and advanced electronic link equalization. Chromatic dispersion compensation can be applied to thereceive side of the demodulator. This module is managed utilizing the Two Wire Interface that is specified in the Common Management Interface Specification (CMIS).

Host Interface

Host Interface	Application Data Rate	Lane Count	Lane Signaling Rate	Modulation
1x400GAUI-8		8	26.5625 GBaud (+100ppm)	PAM4
4x100GAUI-2		8	26.5625 GBaud (+100ppm)	PAM4

Media Interface

Application Bit Rate	Baud Rate	Modulation	FEC
481.108374 Gb/s	60.1385468 GBd	DP-16QAM	oFEC

Absolute Maximum Ratings

Parameter	Symbol	Min.	Typ.	Max.	Units	Notes
Storage Temperature	Ts	-40		85	oC	
Operating Case Temperature	Top	0		75	oC	
Power Supply Voltage	Vcc	-0.3		3.63	V	
Storage Humidity (non-condensation)	RH			85	%	
RX Optical Maximum Input Power				10	dBm	
Short term Operating Case Temperature				80	oC	<24 hours

Recommended Operating Conditions

Parameter	Symbol	Min.	Typ.	Max.	Units	Note
Power Supply Voltage	VCC	3.135		3.465	V	
Operating Case temperature	TC	0		70	°C	
Operating Humidity (no-Condensing)				85	%	
RX Optical input Power				1565	dBm	

Block Diagram of Transceiver

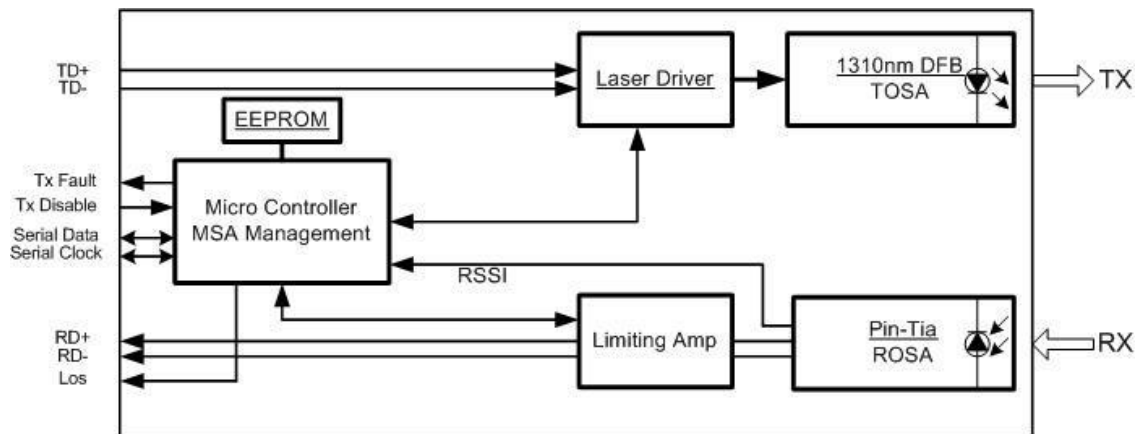

Optical Characteristics

Parameter	Min.	Typ.	Max.	Units	Note
Transmitter Frequency Range	191.3	193.7	196.1	THz	C band 75GHz ITU-T grid. Frequency range over which the specifications hold unless noted otherwise
Laser Frequency Stability	-1.8		1.8	GHz	Frequency stability relative to ITU grid
Laser Frequency Accuracy	-1.8		1.8	GHz	
Laser Frequency Fine Tuning Range	-6.0		6.0	GHz	
Fine Tuning Resolution		100		MHz	
Channel Tuning Speed			60	s	
Laser Line Width			100	kHz	
Transmitter Output Power Range	-10		-6	dBm	
Transmitter Output Disable Time			180	ms	

Output Power Stability	-0.5		0.5	dB	Difference over temperature, time, wavelength and aging
Transmitter Turn-up Time from Cold Start			120	s	
Transmitter OSNR (Inband)	34			dB/0.1nm	
Transmitter Back Reflectance			-24	dB	
Transmitter Output Power with TX Disabled			-20	dBm	
Transmitter Polarization Dependent Power			1.5	dB	Power deference between X and Y polarization
		Receiver			
Receiver Frequency Range	191.3	193.7	196.1	THz	
Input Power Range	-12		0	dBm	Signal power of the channel at the OSNR Penalty <0.5dB
OSNR Sensitivity		22	24	dB/0.1nm	

Electro Characteristics

<i>Parameter</i>	<i>Symbol</i>	<i>Min</i>	<i>Typ.</i>	<i>Max.</i>	<i>Units</i>	<i>Note</i>
	Transmitter					
Signal Rate, each lane			26.5625 ± 100 ppm			GBd
Differential pk-pk Input Voltage Tolerance				900		mVpp
	Receiver					
Signal Rate, each lane			26.5625 ± 100 ppm			GBd
Differential Peak-to-Peak Output Voltage			750	900		mVpp
Transition Time, 20% to 80%			9.5			ps

Pin Assignment and Description

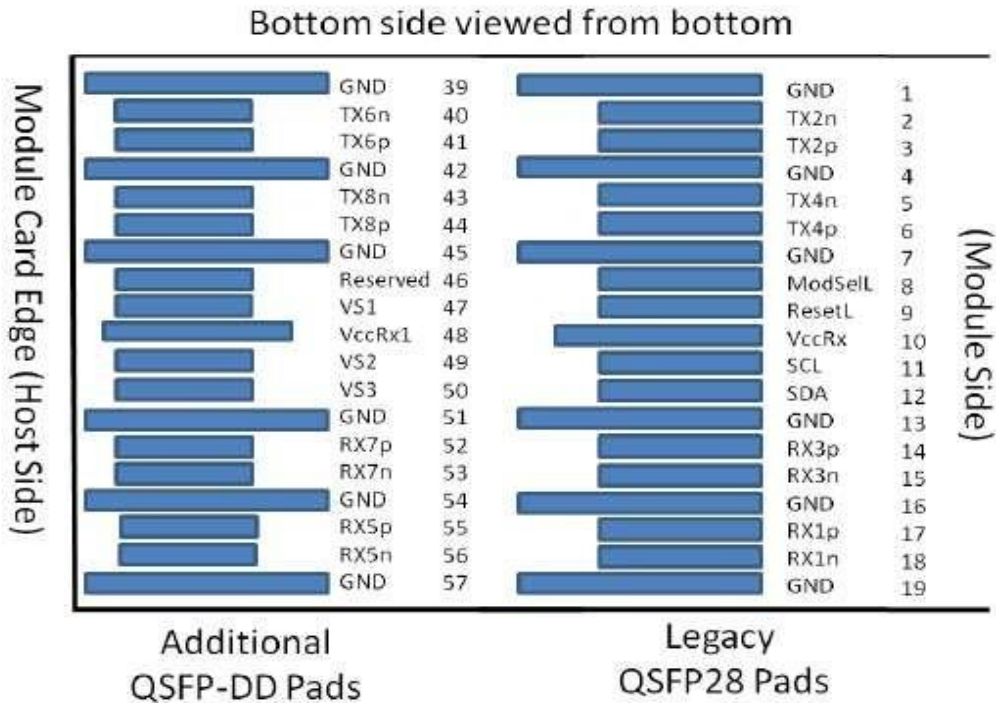
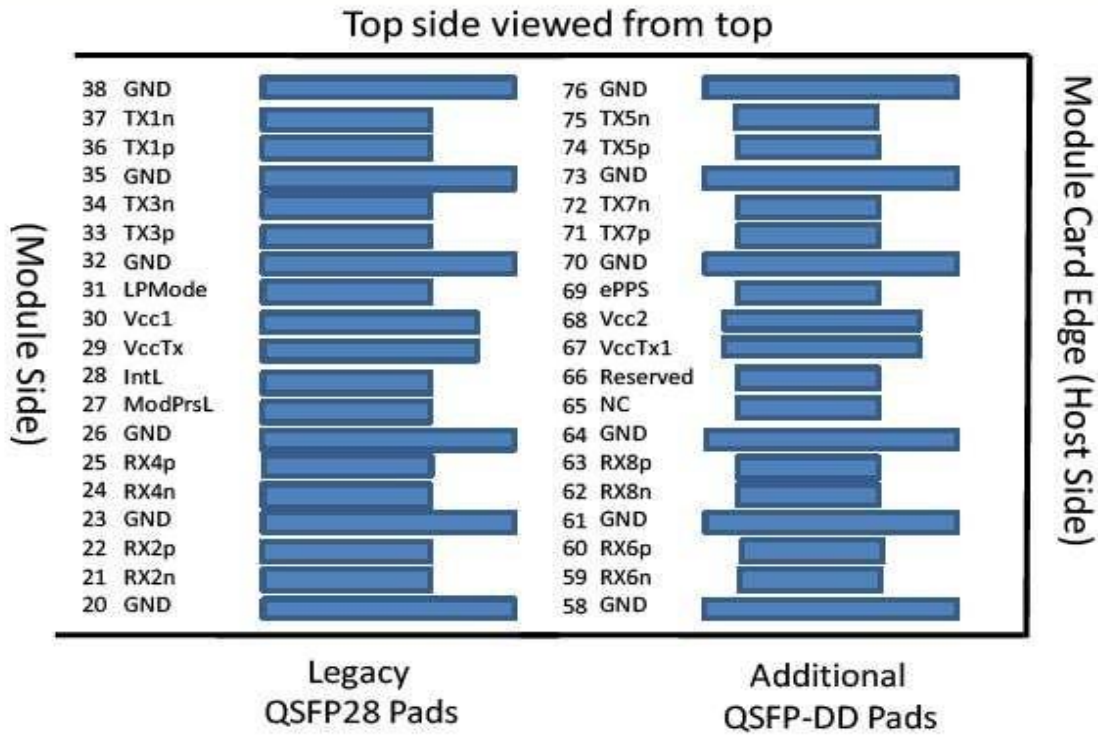

<i>PIN</i>	<i>Logic</i>	<i>Symbol</i>	<i>Name / Description</i>	<i>Note</i>
1		GND	Ground	
2	CML-I	Tx2n	Transmitter inverted data input	
3	CML-I	Tx2p	Transmitter non-inverted data input	
4		GND	Ground	

5	CML-I	Tx4n	Transmitter inverted data input	
6	CML-I	Tx4p	Transmitter non-inverted data input	
7		GND	Ground	
8	LVTTL-I	MoDSeIL	Module Select	
9	LVTTL-I	ResetL	Module Reset	
10		VccRx	+3.3v Receiver Power Supply	
11	LVCNOS- I/O	SCL	2-wire Serial interface clock	
12	LVCNOS- I/O	SDA	2-wire Serial interface data	
13		GND	Ground	
14	CML-O	RX3p	Receiver non-inverted Data Output	
15	CML-O	RX3n	Receiver inverted Data Output	
16		GND	Ground	
17	CML-O	Rx1p	Receiver non-inverted Data Output	
18	CML-O	Rx1n	Receiver inverted Data Output	
19		GND	Ground	
20		GND	Ground	
21	CML-O	Rx2n	Receiver Inverted Data Output	
22	CML-O	Rx2p	Receiver Non-Inverted Data Output	
23		GND	Ground	
24	CML-O	Rx4n	Receiver Inverted Data Output	
25	CML-O	Rx4p	Receiver Non-Inverted Data Output	
26		GND	Ground	
27	LVTTL-O	ModPrsL	Module Present	
28	LVTTL-O	IntL	Interrupt	
29		VccTx	+3.3v Power supply transmitter	
30		Vcc1	+3.3v Power supply	
31	LVTTL-I	InitMode	Initialization mode; In legacy QSFP applications, the InitMode pad is called LPMODE	
32		GND	Ground	
33	CML-I	Tx3p	Transmitter Non-Inverted Data Input	
34	CML-I	Tx3n	Transmitter Inverted Data Input	
35		GND	Ground	
36	CML-I	Tx1p	Transmitter Non-Inverted Data Input	
37	CML-I	Tx1n	Transmitter Inverted Data Input	

38		GND	Ground	
39		GND	Ground	
40	CML-I	Tx6n	Transmitter Inverted Data Input	
41	CML-I	Tx6p	Transmitter Non-Inverted Data Input	
42		GND	Ground	
43	CML-I	Tx8n	Transmitter Inverted Data Input	
44	CML-I	Tx8p	Transmitter Non-Inverted Data Input	
45		GND	Ground	
46		Reserved	For future use	
47		VS1	Module Vendor Specific 1	
48		VccRx1	3.3V Power Supply	
49		VS2	Module Vendor Specific 2	
50		VS3	Module Vendor Specific 3	
51		GND	Ground	
52	CML-O	Rx7p-	Receiver Non-Inverted Data Output	
53	CML-O	Rx7n	Receiver Inverted Data Output	
54		GND	Ground	
55	CML-O	Rx5p-	Receiver Non-Inverted Data Output	
56	CML-O	Rx5n	Receiver Inverted Data Output	
57		GND	Ground	
58		GND	Ground	
59	CML-O	Rx6n-	Receiver Inverted Data Output	
60	CML-O	Rx6p	Receiver Non-Inverted Data Output	
61		GND	Ground	
62	CML-O	Rx8n	Receiver Inverted Data Output	
63	CML-O	Rx8p	Receiver Non-Inverted Data Output	
64		GND	Ground	
65		NC	No connect	

Dimensions

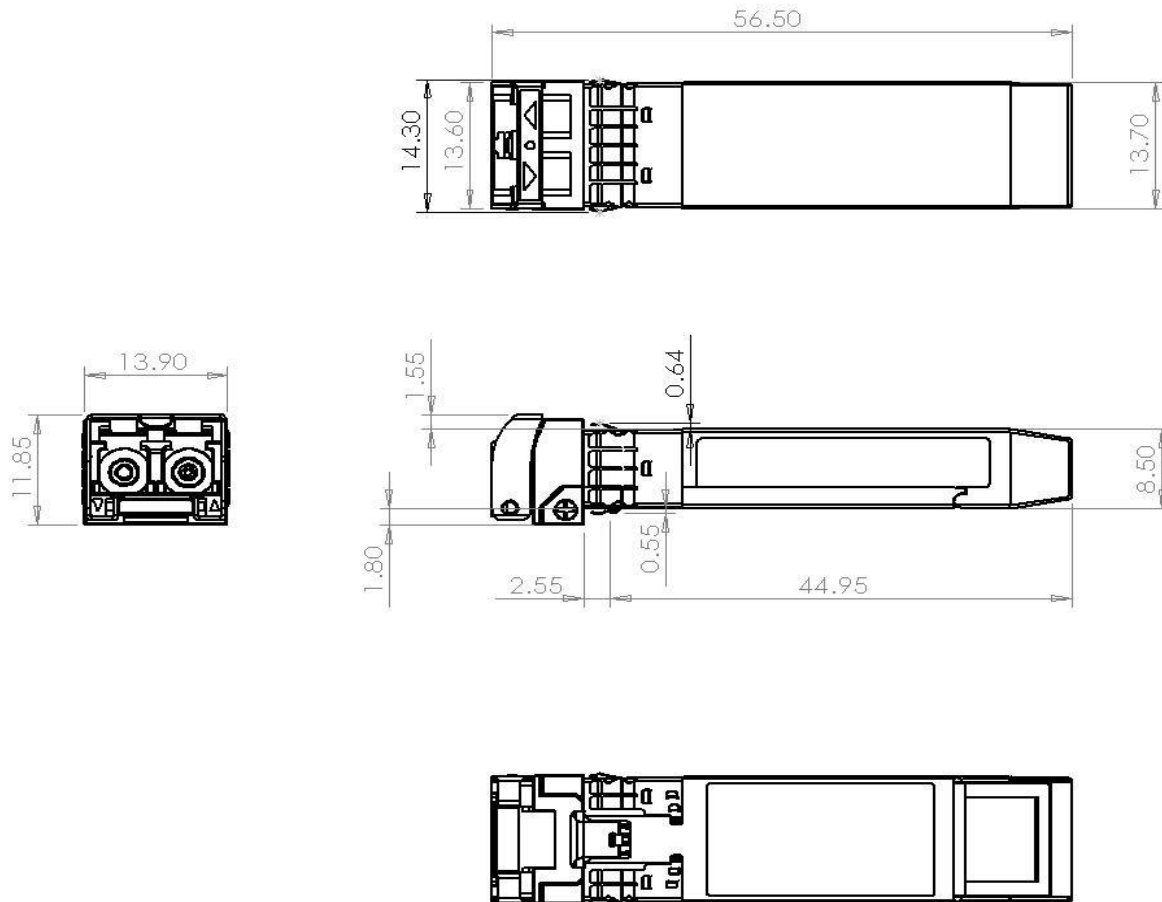

Optical Receptacle Cleaning Recommendations:

All fiber stubs inside the receptacle portions were cleaned before shipment. In the event of contamination of the optical ports, the recommended cleaning process is the use of forced nitrogen. If contamination is thought to have remained, the optical ports can be cleaned using a NTT international Cletop® stick type and HFE7100 cleaning fluid. Before the mating of patch-cord, the fiber end should be cleaned up by using Cletop® cleaning cassette.

Cleaning of patch-cord



Cleaning of fiber stub

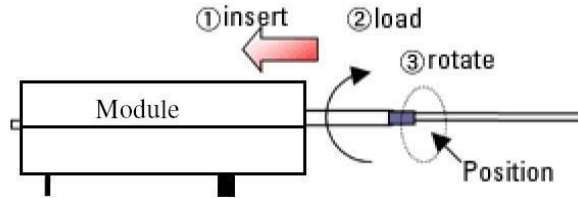

1. Insert
Ensure that stick is held straight when inserting into sleeve.
2. Load
Apply sufficient pressure (approx 600-700g) to ensure ferrule a little depressed in sleeve.
3. Rotate
Rotate stick clockwise 4-5 times, while ensuring direct contact with ferrule end-face is maintained.

*Notice: Number of possible wipes:
Maintenance (repair) ~1 use / piece
Equipment construction: 4 uses / piece (max.)*

Note: The pictures were extracted from NTT-ME website. And the Cletop® is a trademark registered by NTT-ME

Ordering Information

Model Number	Part Number	Reach	Temperature
AQSFP-DD-ZR+	OPDY-SC0-xx-CB	120km	0°C to 70°C

Modification History

Revision	Date	Description
A1	May 2023	Initial Release

Note: All information contained in this document is subject to change without notice.