

**Alpha Bridge  
AQSFP-DD-FR4  
Datasheet**



## Features

- QSFP-DD MSA compliant
- 4 CWDM lanes MUX/DEMUX design
- 100G Lambda MSA 400G-FR4 Specification compliant
- Up to 2km transmission on single mode fiber (SMF) with FEC
- 8x53.125Gb/s electrical interface (400GAUI-8)
- Data Rate 106.25Gbps (PAM4) per channel
- Maximum power consumption 12W
- Duplex LC connector
- Operating case temperature: 0°C ~70°C
- RoHS compliant

## Applications

- Data Center Interconnect
- 400G Ethernet
- Infiniband interconnects
- Enterprise networking

## Description

This product is a 400Gb/s Quad Small Form Factor Pluggable-double density (QSFP-DD) optical module designed for 2km optical communication applications. The module converts 8 channels of 50Gb/s (PAM4) electrical input data to 4 channels of CWDM optical signals, and multiplexes them into a single channel for 400Gb/s optical transmission. Reversely, on the receiver side, the module optically de-multiplexes a 400Gb/s optical input into 4 channels of CWDM optical signals, and converts them to 8 channels of 50Gb/s (PAM4) electrical output data.

The center wavelengths of the 4 CWDM channels are 1271, 1291, 1311 and 1331nm as members of the CWDM wavelength grid defined in ITU-T G.694.2. It contains a duplex LC connector for the optical interface and a 76-pin connector for the electrical interface. To minimize the optical dispersion in the long-haul system, single-mode fiber (SMF) has to be applied in this module. Host FEC is required to support up to 2km fiber transmission.

The product is designed with form factor, optical/electrical connection and digital diagnostic interface according to the QSFP-DD Multi-Source Agreement (MSA). Type 2 it has been designed to meet the harshest external operating conditions including temperature, humidity and EMI interference.

## Absolute Maximum Ratings

Parameter	Symbol	Min	Max	Units	Note
Storage Temperature	Tst	-40	85	°C	
Operating Case Temperature	Top	0	70	°C	
Supply Voltage	Vcc	-0.5	3.6	V	
Humidity (non-condensation)	RH	0	85	%	
Damage Threshold, each Lane	THd	4.5		dBm	

## Recommended Operating Conditions

Parameter	Symbol	Min	Typical	Max	Unit	Notes
Operating Case Temperature	Tca	0		70	°C	
Supply Voltage	Vcc	3.135	3.3	3.465	V	
Data Rate, each Lane	fd		26.5625		GBd	PAM4
Data Rate Accuracy		-100		100	ppm	
Pre-FEC Bit Error Ratio				2.4x10 <sup>-4</sup>		
Post-FEC Bit Error Ratio				1x10 <sup>-12</sup>		1
Link Distance	D	0.002		2	Km	2

Notes:

1. FEC provided by host system.
2. FEC required on host system to support maximum distance.

**Diagnostics Monitoring**

Parameter	Symbol	Accuracy	Unit	Notes
Temperature monitor absolute error	DMI_Temp	± 3	°C	
Supply voltage monitor absolute error	DMI_VCC	± 0.1	V	
Channel RX power monitor absolute error	DMI_RX_Ch	± 2	dB	1
Channel Bias current monitor	DMI_Ibias_Ch	± 10%	mA	
Channel TX power monitor absolute error	DMI_TX_Ch	± 2	dB	1

Notes:

1. Due to measurement accuracy of different single mode fibers, there could be an additional +/-1 dB fluctuation, or a +/- 3 dB total accuracy.

**Optical Characteristics**

Parameter	Symbol	Min	Typical	Max	Unit	Notes
Center Wavelength nm	L0	1264.5	1271	1277.5	nm	
	L1	1284.5	1291	1297.5		
	L2	1304.5	1311	1317.5		
	L3	1324.5	1331	1337.5		
Data Rate, each Lane		53.125 ± 100 ppm			GBd	
Modulation Format			PAM4			
<b>Transmitter</b>						
Side-mode Suppression Ratio	SMSR	30			dB	
Total Average Launch Power	P <sub>T</sub>			9.3	dBm	
Average Launch Power, each Lane	PAVG	-3.3		3.5	dBm	1
Optical Modulation Amplitude (OMA <sub>outer</sub> ), each Lane	POMA	-0.3		3.7	dBm	2
Launch Power in OMA <sub>outer</sub> minus TDECQ, each Lane		-1.7			dB	For ER ≥ 4.5dB
		-1.6			dB	For ER ≤ 4.5dB
Transmitter and Dispersion Eye Closure for PAM4, each Lane	TDECQ			3.4	dB	
TDECQ -10*log <sub>10</sub> (C <sub>eq</sub> ), each Lane				3.4	dB	3
Extinction Ratio	ER	3.5			dB	
Difference in Launch Power between any Two Lanes (OMA <sub>outer</sub> )				4	dB	
RIN17.1 OMA	RIN			-136	dB/Hz	
Optical Return Loss Tolerance	TOL			17.1	dB	
Transmitter Reflectance	R <sub>T</sub>			-26	dB	
Transmitter Transition Time				17	ps	
Average Launch Power of OFF Transmitter, each Lane	P <sub>off</sub>			-20	dBm	
<b>Receiver</b>						
Damage Threshold, each Lane	THd	4.5			dBm	
Average Receiver Power, each Lane		-7.3		3.5	dBm	
Receiver Power (OMA <sub>outer</sub> ), each Lane				3.7	dBm	
Difference in Receiver Power between any Two Lanes (OMA <sub>outer</sub> )				4.1	dB	
Receiver Sensitivity (OMA <sub>outer</sub> ), each Lane	SEN	Equation (1)			dBm	
Stressed Receiver Sensitivity in OMA <sub>outer</sub>	SRS			-2.6	dBm	1
Receiver Reflectance	R <sub>R</sub>			-26	dB	
LOS Assert	LOSA	-20			dBm	
LOS De-assert	LOSD			-10.3	dBm	
LOS Hysteresis	LOSH	0.5			dB	
<b>Stressed Conditions for Stress Receiver Sensitivity (Note 8)</b>						
Stressed Eye Closure for PAM4 (SECQ), Lane under Test			3.4		dB	
SECQ-10*log <sub>10</sub> (C <sub>eq</sub> ), Lane under Test				3.4	dB	

OMA <sub>outer</sub> of each Aggressor Lane		1.5		dBm
---	--	-----	--	-----

- Notes:
1. Average launch power, each lane (min) is informative and not the principal indicator of signal strength. A transmitter with launch power below this value cannot be compliant, however, a value above this does not ensure compliance.
  2. Even if the TDECQ < 1.4dB for an extinction ratio of  $\geq 4.5$ dB or TDECQ < 1.3dB for an extinction ratio of < 4.5dB, the OMA<sub>outer</sub> (min) must exceed the minimum value specified here.
  3. Ceq is a coefficient defined in IEE Std 802.3-2018 clause 121.8.5.3 which accounts for reference equalizer noise enhancement.
  4. Average receiver power, each lane (min) is informative and not the principal indicator of signal strength. A received power below this value cannot be compliant; however, a value above this does not ensure compliance.
  5. The receiver shall be able to tolerate, without damage, continuous exposure to an optical input signal having this average power level.
  6. Receiver sensitivity (OMA<sub>outer</sub>) is informative and is defined for a transmitter with a value of SECQ up to 3.4dB. Receiver sensitivity should meet Equation (1), which is illustrated in Figure 4.  

$$RS = \max(-4.6, SECQ - 6.0) \text{ dBm} \quad (1)$$

Where:

RS is the receiver sensitivity

SECQ is the SECQ of the transmitter used to measure the receiver sensitivity.

7. Measured with conformance test signal at TP3 for the BER equal to  $2.4 \times 10^{-4}$
8. These test conditions are for measuring stressed receiver sensitivity. They are not characteristics of the receiver.

### Electronical Characteristics

Parameter	Symbol	Min	Typical	Max	Unit	Notes
Power Consumption				12	W	
Supply Current	<i>I<sub>cc</sub></i>			3.64	A	
<b>Transmitter (each Lane)</b>						
Signaling Rate, each Lane	<i>TP1</i>	26.5625 ± 100 ppm			GBd	
Differential pk-pk input Voltage Tolerance	<i>TP1a</i>	900			mVpp	1
Differential Termination Mismatch	<i>TP1</i>			10	%	
Differential Input Return Loss	<i>TP1</i>	IEEE 802.3-2015 Equation (83E-5)			dB	
Differential to Common Mode Input Return Loss	<i>TP1</i>	IEEE802.3-2015 Equation (83E-6)			dB	
Module Stressed Input Test	<i>TP1a</i>	See IEEE 802.3bs 120E 3.4.1				2
Single-ended Voltage Tolerance Range (Min)	<i>TP1a</i>		-0.4 to 3.3		V	
DC Common Mode Input Voltage	<i>TP1</i>	-350		2850	mV	3
<b>Receiver (each Lane)</b>						
Differential Peak-to-Peak Output Voltage	<i>TP4</i>			900	mVpp	
AC Common Mode Output Voltage, RMS	<i>TP4</i>			17.5	mV	
Differential Termination Mismatch	<i>TP4</i>			10	%	
Differential Output Return Loss	<i>TP4</i>	IEEE 802.3-2015 Equation (83E-2)			mV	
Common to Differential Mode Conversion Return Loss	<i>TP4</i>	IEEE 802.3-2015 Equation (83E-3)				
Transition Time, 20% to 80%	<i>TP4</i>	9.5			ps	
Near-end Eye Symmetry Mask Width (ESMW)	<i>TP4</i>		0.265		UI	
Near-end Eye Height, Differential	<i>TP4</i>	70			mV	
Far-end Eye Symmetry Mask Width (ESMW)	<i>TP4</i>		0.2		UI	
Far-end Eye Height, Differential	<i>TP4</i>	30			mV	
Far-end Pre-cursor ISI Ratio	<i>TP4</i>	-4.5		2.5	%	

Common Mode Output Voltage (Vcm)	TP4	-350	2850	mV	3
----------------------------------	-----	------	------	----	---

Notes:

1. With the exception to IEEE 802.3bs 120E.3.1.2 that the pattern is PRBS31Q or scrambled idle.
2. Meets BER specified in IEEE 802.3bs 120E 1.1
3. DC common mode voltage generated by the host. Specification includes effects of ground offset voltage.

**Transceiver Block Diagram**

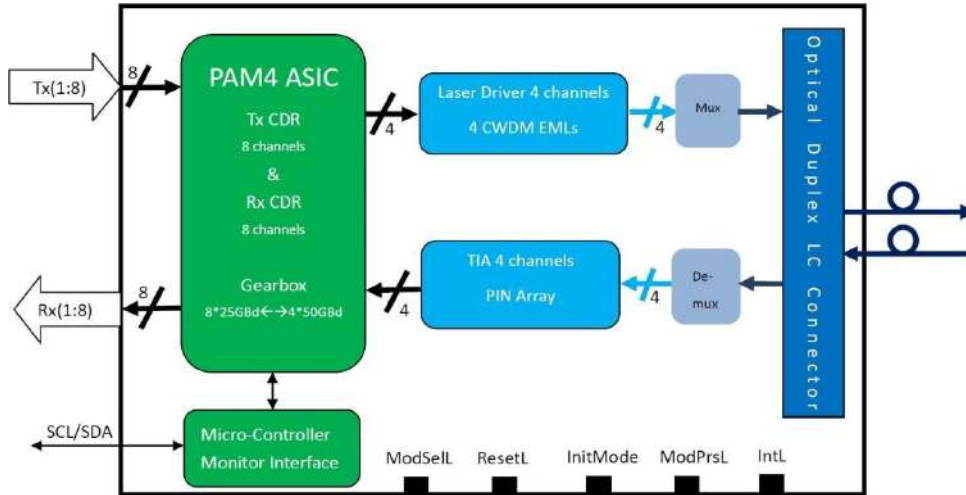

**Pin Assignment and Description**

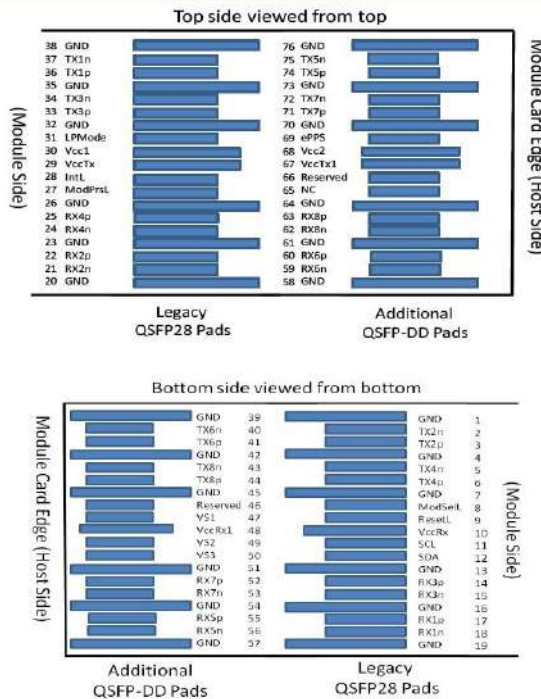

**Pin Description**

PIN	Logic	Symbol	Name/Description	Note
1		GND	Ground	1
2	CML-I	Tx2n	Transmitter inverted data input	
3	CML-I	Tx2p	Transmitter non-inverted data input	
4		GND	Ground	1
5	CML-I	Tx4n	Transmitter inverted data input	
6	CML-I	Tx4p	Transmitter non-inverted data input	

7		GND	Ground	1
8	LVTTTL-I	MoDSeLL	Module Select	
9	LVTTTL-I	ResetL	Module Reset	
10		VccRx	+3.3v Receiver Power Supply	2
11	LVC MOS-I/O	SCL	2-wire Serial interface clock	
12	LVC MOS-I/O	SDA	2-wire Serial interface data	
13		GND	Ground	1
14	CML-O	Rx3p	Receiver non-inverted Data Output	
15	CML-O	Rx3n	Receiver inverted Data Output	
16		GND	Ground	1
17	CML-O	Rx1p	Receiver non-inverted Data Output	
18	CML-O	Rx1n	Receiver inverted Data Output	
19		GND	Ground	1
20		GND	Ground	1
21	CML-O	Rx2n	Receiver Inverted Data Output	
22	CML-O	Rx2p	Receiver Non-Inverted Data Output	
23		GND	Ground	1
24	CML-O	Rx4n	Receiver Inverted Data Output	
25	CML-O	Rx4p	Receiver Non-Inverted Data Output	
26		GND	Ground	1
27	LVTTTL-O	ModPrsL	Module Present	
28	LVTTTL-O	IntL	Interrupt	
29		VccTx	+3.3v Power supply transmitter	2
30		Vcc1	+3.3v Power supply	2
31	LVTTTL-I	LPMoDe	Low Power Mode	2
32		GND	Ground	1
33	CML-I	Tx3p	Transmitter Non-Inverted Data Input	
34	CML-I	Tx3n	Transmitter Inverted Data Input	
35		GND	Ground	1
36	CML-I	Tx1p	Transmitter Non-Inverted Data Input	
37	CML-I	Tx1n	Transmitter Inverted Data Input	
38		GND	Ground	1
39		GND	Ground	1
40	CML-I	Tx6n	Transmitter Inverted Data Input	
41	CML-I	Tx6p	Transmitter Non-Inverted Data Input	
42		GND	Ground	1
43	CML-I	Tx8n	Transmitter Inverted Data Input	
44	CML-I	Tx8p	Transmitter Non-Inverted Data Input	
45		GND	Ground	1
46		Reserved	For future use	
47		VS1	Module Vendor Specific 1	
48		VccRx1	3.3V Power Supply	
49		VS2	Module Vendor Specific 2	
50		VS3	Module Vendor Specific 3	
51		GND	Ground	1
52	CML-O	Rx7p-	Receiver Non-Inverted Data Output	
53	CML-O	Rx7n	Receiver Inverted Data Output	
54		GND	Ground	1
55	CML-O	Rx5p-	Receiver Non-Inverted Data Output	
56	CML-O	Rx5n	Receiver Inverted Data Output	
57		GND	Ground	1
58		GND	Ground	1
59	CML-O	Rx6n-	Receiver Inverted Data Output	
60	CML-O	Rx6p	Receiver Non-Inverted Data Output	
61		GND	Ground	1

62	CML-O	Rx8n	Receiver Inverted Data Output	
63	CML-O	Rx8p	Receiver Non-Inverted Data Output	
64		GND	Ground	1
65		NC	No connect	3
66		Reserved	For future use	3
67		VccTx1	3.3V Power Supply	2
68		Vcc2	3.3V Power Supply	2
69	LVTTL-I	ePPS	Precision Time Protocol (PTP) reference clock input	3
70		GND	Ground	1
71	CML-I	Tx7p	Transmitter Non-Inverted Data Input	
72	CML-I	Tx7n	Transmitter Inverted Data Input	
73		GND	Ground	1
74	CML-I	Tx5p	Transmitter Non-Inverted Data Input	
75	CML-I	Tx5n	Transmitter Inverted Data Input	
76		GND	Ground	1

**Notes:**

1. QSFP-DD uses common ground (GND) for all signals and supply (power). All are common within the QSFP-DD module and all module voltages are referenced to this potential unless otherwise noted. Connect these directly to the host board signal-common ground plane.
2. VccRx, RccRx1, Vcc1, Vcc2, VccTx and VccTx1 shall be applied concurrently. Requirements defined for the host side of the Host Card Edge Connector. VccRx, VccRx1, Vcc1, Vcc2, VccTx and VccTx1 may be internally connected within the module in any combination. The corrector Vcc pins are each rated for a maximum current of 1000mA.
3. All Vendor Specific, Reserved, No connect and ePPS (if not used) pins may be terminated with 50 Ohms to ground on the host. Pad 65 (No Connect) shall be left unconnected within the module. Vendor specific and Reserved pads shall have an impedance to GND that is greater than 10k ohms and less than 100pF.
4. Plug Sequence specifies the mating sequence of the host connector and module. The sequence is 1A, 2A, 3A, 1B, 2B, 3B. (see Figure 2 for pad locations) Contact sequence A will make, then break contact with additional QSFP-DD pads. Sequence 1A, 1B will then occur simultaneously, followed by 2A, 2B, followed by 3A, 3B.

**Recommended Power Supply Filter**

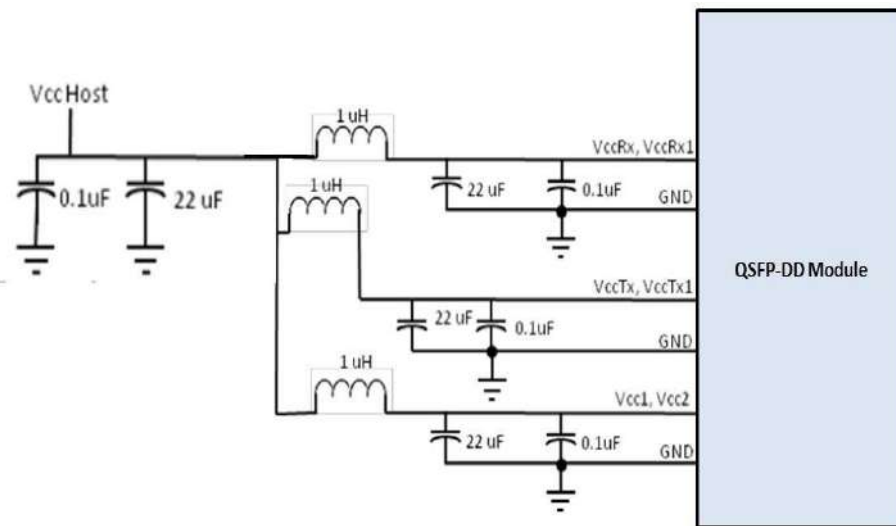

**Host Board Power Supply Filtering**

**Dimensions**

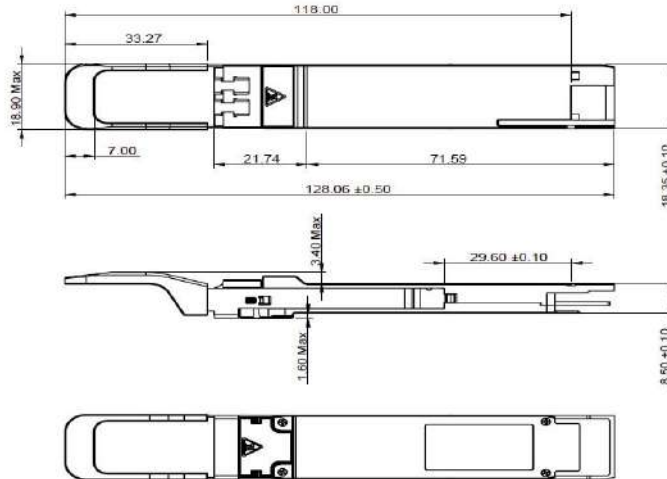

**Optical Receptacle Cleaning Recommendations**

All fiber stubs inside the receptacle portions were cleaned before shipment. In the event of contamination of the optical ports, the recommended cleaning process is the use of forced nitrogen. If contamination is thought to have remained, the optical ports can be cleaned using a NTT international Cletop<sup>®</sup> stick type and HFE7100 cleaning fluid. Before the mating of patch-cord, the fiber end should be cleaned up by using Cletop<sup>®</sup> cleaning cassette.

<p><b>Cleaning of patch-cord</b></p>	<p><b>Cleaning of fiber stub</b></p> <p>① insert    ② load    ③ rotate Position</p> <p>1. Insert Ensure that stick is held straight when inserting into sleeve.</p> <p>2. Load Apply sufficient pressure (approx 600-700g) to ensure ferrule a little depressed in sleeve.</p> <p>3. Rotate Rotate stick clockwise 4-5 times, while ensuring direct contact with ferrule end-face is maintained.</p> <p><i>Notice: Number of possible wipes: Maintenance (repair) - 1 use / piece Equipment construction: 4 uses / piece (max.)</i></p>
--------------------------------------	---

Note: The pictures were extracted from NTT-ME website. And the Cletop<sup>®</sup> is a trademark registered by NTT-ME

**Ordering Information**

Model Number	Part Number	Voltage	Temperature
AQSFP-DD FR4	OPDY-S02-13-CB	3.3V	0°C to 70 °C