

**Alpha Bridge**  
**AQSFP-40G-SR4,3**  
**Datasheet**

### Features

- 4 independent full-duplex channels
- Up to 11.2Gb/s data rate per channel
- MTP/MPO optical connector
- QSFP+ MSA compliant
- Digital diagnostic capabilities
- Up to 300m transmission on OM3 multi-mode fiber
- CML compatible electrical I/O
- Single 3.3V power supply
- Commercial case temperature: 0 to 70oC
- XLPPi electric interface
- Maximum power consumption 1.5W
- RoHS-6 compliant

### Applications

- Rack to Rack
- Data Center
- Infiniband QDR, DDR and SDR
- 40G Ethernet

### Description

This product is a parallel 40Gb/s Qual Small Form Factor Pluggable (QSFP+) optical module. It provides increased port density and total system cost saving. The QSFP+ full-duplex module offers 4 independent transmit and receive channels, each capable of 10Gb/s operation for an aggregate data rate of 40Gb/s on 300 meters of OM3 Multi-mode fiber. An optical fiber ribbon cable with an MTP/MPO connector can be plugged into the QSFP+ module receptacle. Proper alignment is ensured by the guide pins inside the receptacle. The cable usually can not be twisted for proper channels to channel alignment. Electrical connection is achieved through an MSA-compliant 38-pin edge type connector.

The module operates by a single 3.3V power supply. LVCMOS/LVTTL global control signals, such as Module Present, Reset, Interrupt and Low Power Mode, are available with the modules. A 2-wire serial interface is available to send and receive more complex control signals, and to receive digital diagnostic information. Individual channels can be addressed and unused channels can be shut down for maximum design flexibility.

The product is designed with form factor, optical/electrical connection and digital diagnostic interface according to the QSFP+ Multi-Source Agreement (MSA). It has been designed to meet the harshest external operating conditions including temperature, Humidity and EMI interface. The module offers very high functionality and feature integration, accessible via a two-wire serial interface

### Absolute Maximum Ratings

Parameter	Symbol	Min.	Max.	Units
Storage Ambient Temperature	T <sub>STG</sub>	-40	85	°C
Supply Voltage	V <sub>CC</sub>	0	70	°C
Operating Case Temperature	T <sub>OP</sub>	-0.5	3.6	V
Relative Humidity (non-condensation)	RH	0	85	%
Damage Threshold, each Lane	THd	3.4		dBm

### Recommended Operating Conditions

Parameter	Symbol	Min.	Typ.	Max.	Units
Operating Temperature	T <sub>OP</sub>	0		+70	°C
Power Supply Voltage	V <sub>CC</sub>	3.135	3.3	3.465	V
Data Rate, each Lane			10.3125	11.2	Gb/s
Control Input Voltage High		2		V <sub>CC</sub>	V
Control Input Voltage Low		0		0.8	V
Link Distance (OM3)	D			300	m

**Diagnosics**

Parameter	Symbol	Accuracy	Units	Notes
Temperature monitor absolute error	DMI_Temp	±3	°C	Over operating temperature range
Supply voltage monitor absolute error	DMI_VCC	±0.1	V	Over full operating range
Channel RX power monitor absolute error	DMI_RX_Ch	±2	dB	1
Channel Bias current monitor	DMI_Ibias_Ch	±10%	mA	Ch1-Ch4
Channel TX power monitor absolute error	DMI_TX_Ch	±2	dB	1

Notes: 1. Due to measurement accuracy of different single mode fibers, there could be an additional +/-1 dB fluctuation, or a +/- 3 dB total accuracy.

**Optical Characteristics**

Parameter	Symbol	Min	Type	Max	Unit	Notes
Center Wavelength	$\lambda_C$	840	850	860	nm	1
<b>Transmitter</b>						
RMS Spectral Width	$\Delta\lambda_{ms}$			0.45	nm	1
Average Launch Power, each Lane	$P_{AVG}$	-7.3		1	dBm	2
Optical Modulation Amplitude (OMA) each Lane	$P_{OMA}$	-4.3		3	dBm	1
Difference in Launch Power between any Two Lanes (OMA)	$P_{tx,diff}$			4	dB	
Peak Power, each Lane	$PP_T$			4	dBm	
Launch Power in OMA minus Transmitter and Dispersion Penalty (TDP) each Lane		-6.5			dBm	
TDP, each lane	$TDP$			3.5	dB	
Extinction Ratio	$ER$	3			dB	
Relative Intensity Noise	$RIN$			-128	dB/Hz	12dB reflection
Optical Return Loss Tolerance	$TOL$			12	dB	
Encircled Flux		$\geq 86\%$ at 19um $\leq 30\%$ at 4.5um				
Transmitter Eye Mask Definition (X1, X2, X3, Y1, Y2, Y3)		{0.23,0.34,0.43,0.27,0.35,0.4}				
Average Launch Power OFF Transmitter each Lane	$P_{off}$			-30	dBm	
<b>Receiver</b>						
Damage Threshold, each Lane	$TH_d$	3.4			dBm	3
Average Receive Power, each Lane		-9.9		2.4	dBm	
Receiver Reflectance	$R_R$			-12	dB	
Receiver Power (OMA) each Lane				3	dBm	
Receiver Sensitivity (OMA) each Lane	$SEN$			-11.1	dBm	
Stressed Receiver Sensitivity (OMA) each Lane				-7.5	dBm	4
Peak Power, each Lane	$PP_R$			4	dBm	
LOS Assert	$LOSA$	-30			dBm	
LOS Deassert	$LOSD$			-12	dBm	
LOS Hysteresis	$LOSH$	0.5			dB	
<b>Conditions of Stress Receiver Sensitivity Test (Note 5)</b>						
Vertical Eye Closure Penalty, each Lane			1.9		dB	
Stressed Eye J2 Jitter, each Lane			0.3		UI	
Stressed Eye J9 Jitter, each Lane			0.47		UI	
OMA of each aggressor Lane			-0.4		dBm	

**Notes:**

See Table 1. Trade-offs are available among center wavelength, spectral width, and minimum OMA.

2. The maximum transmitter average optical power of 1.0 dBm is well within the guardband of receiver overload specifications of commercially available 10GBASE-SR SFP+ transceivers offered by optech and other vendors..

3. The receiver shall be able to tolerate, without damage, continuous exposure to a modulated optical input signal having this power level on one lane. The receiver does not have to operate correctly at this input power.

4. Measured with conformance test signal at receiver input for BER=1x10-12

5. Vertical eye closure penalty and stressed eye jitter are test conditions for measuring stressed receiver sensitivity. They are not characteristics of the receiver.

RMS Spectral Width (nm)									
Center Wavelength (nm)	Up to 0.05	0.05 to 0.1	0.1 to 0.15	0.15 to 0.2	0.2 to 0.25	0.25 to 0.3	0.3 to 0.35	0.35 to 0.4	0.4 to 0.45
840 to 842	-4.2	-4.2	-4.1	-4.1	-3.9	-3.8	-3.5	-3.2	-2.8
842 to 844	-4.2	-4.2	-4.2	-4.1	-3.9	-3.8	-3.6	-3.3	-2.9
844 to 846	-4.2	-4.2	-4.2	-4.1	-4.0	-3.8	-3.6	-3.3	-2.9
846 to 848	-4.3	-4.2	-4.2	-4.1	-4.0	-3.8	-3.6	-3.3	-2.9
848 to 850	-4.3	-4.2	-4.2	-4.1	-4.0	-3.8	-3.6	-3.3	-3.0
850 to 852	-4.3	-4.2	-4.2	-4.1	-4.0	-3.8	-3.6	-3.4	-3.0
852 to 854	-4.3	-4.2	-4.2	-4.1	-4.0	-3.9	-3.7	-3.4	-3.1
854 to 856	-4.3	-4.3	-4.2	-4.1	-4.0	-3.9	-3.7	-3.4	-3.1
856 to 858	-4.3	-4.3	-4.2	-4.1	-4.0	-3.9	-3.7	-3.5	-3.1
858 to 860	-4.3	-4.3	-4.2	-4.2	-4.1	-3.9	-3.7	-3.5	-3.2

**Electronical Characteristics**

Parameter	Symbol	Min.	Typ.	Max.	Units	Note
Power Consumption				1.5	W	
Supply Current	lcc			450	mA	
Transceiver Power-on Initialization Time				2000	ms	1
Transmitter (each lane) Single-ended Input Voltage Tolerance (Note 2)		-0.3		4	V	Referred to TP1 signal common
AC Common Mode Input Voltage Tolerance		15			mV	RMS
Differential Input Voltage Swing Threshold		50			mVpp	LOSA Threshold
Differential Input Voltage Swing	$V_{in,pp}$	180		1200	mVpp	
Differential Input Impedance	$Z_{in}$	90	100	110	Ohm	
Differential Input Return Loss		See IEEE 802.3ba 86A.4.11			dB	10MHz-11.1GHz
J2 Jitter Tolerance	Jt2	0.17			UI	
J9 Jitter Tolerance	Jt9	0.29			UI	
Data Dependent Pulse Width						
Shrinkage (DDPWS) Tolerance		0.07			UI	
Eye Mask Coordinates (X1, X2, Y1, Y2)		0.11, 0.31, 95, 350			UI / mV	Hit Ratio=5x10 <sup>-5</sup>
Receiver (each Lane)						
Single-ended Output Voltage		-0.3		4	V	Referred to signal common

AC Common Mode Output Voltage				7.5	mV	RMS
Differential Output Voltage Swing	Vout,pp	600		800	mVpp	
Differential Output Impedance	Zout	90	100	110	Ohm	
Termination Mismatch at 1MHz				5	%	
Differential Output Return Loss	See IEEE 802.3ba 86A.4.2.1				dB	10MHz~11.1GHz
Common Mode Output Return Loss	See IEEE 802.3ba 86A.4.2.2				dB	10MHz~11.1GHz
Output Transition Time		28			ps	20% to 80%
J2 Jitter Output	Jo2			0.42	UI	
J9 Jitter Output	Jo9			0.65	UI	

Notes:

1. The receiver shall be able to tolerate, without damage, continuous exposure to a modulated optical input signal having this power level on one lane. The receiver does not have to operate correctly at this input power.
2. Measured with conformance test signal at receiver input for BER = 1x10<sup>-12</sup>.
3. Vertical eye closure penalty and stressed eye jitter are test conditions for measuring stressed receiver sensitivity. They are not characteristics of the receiver.

**Pin Assignment**

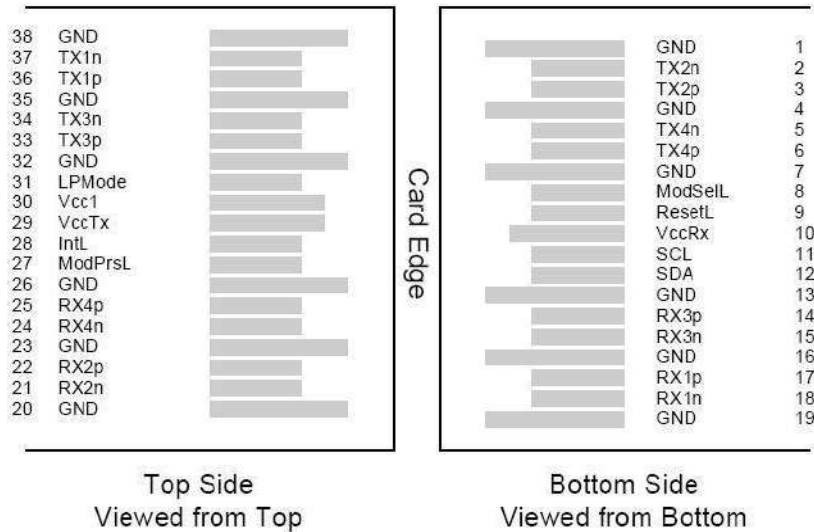

**Pin Description**

PIN	Logic	Symbol	Description	Note
1		GND	Ground	1
2	CML-I	Tx2n	Transmitter Inverted Data Input	
3	CML-I	Tx2p	Transmitter Non-Inverted Data output	
4		GND	Ground	1
5	CML-I	Tx4n	Transmitter inverted Data Input	
6	CML-I	Tx4p	Transmitter Non-Inverted Data output	
7		GND	Ground	1
8	LVTLL-I	ModSelL	Module Select	
9	LVTLL-I	ResetL	Module Reset	
10		VccRx	+3.3V Power Supply Receiver	2
11	LVC MOS-I/O	SCL	2-Wire Serial Interface Clock	
12	LVC MOS-I/O	SDA	2-Wire Serial Interface Data	
13		GNC	Ground	
14	CML-O	Rx3p	Receiver Non-Inverted Data output	
15	CML-O	Rx3n	Receiver Inverted Data output	
16		GND	Ground	1
17	CML-O	Rx1p	Receiver Non-Inverted Data Output	
18	CML-O	Rx1n	Receiver Inverted Data Output	
19		GND	Ground	1
20		GND	Ground	1
21	CML-O	Rx2n	Receiver Inverted Data output	
22	CML-O	Rx2p	Receiver Non-Inverted Data output	
23		GND	Ground	1
24	CML-O	Rx4n	Receiver Inverted Data output	1
25	CML-O	Rx4p	Receiver Non-Inverted Data output	
26		GND	Ground	1
27	LVTTL-O	ModPrsL	Module Present	
28	LVTTL-O	IntL	Interrupt	
29		VccTx	+3.3V Power Supply transmitter	2
30		Vcc1	+3.3V Power Supply	2
31	LVTTL-I	LPMODE	Low Power Mode	
32		GND	Ground	1
33	CML-I	Tx3p	Transmitter Non-Inverted Data Input	
34	CML-I	Tx3n	Transmitter Inverted Data Output	
35		GND	Ground	1
36	CML-I	Tx1p	Transmitter Non-Inverted Data Input	
37	CML-I	Tx1n	Transmitter Inverted Data Output	
38		GND	Ground	1

**Notes:**

1. GND is the symbol for signal and supply (power) common for QSFP+ modules. All are common within the QSFP+ module and all module voltages are referenced to this potential unless otherwise noted. Connect these directly to the host board signal common ground plane.
2. VccRx, Vcc1 and VccTx are the receiver and transmitter power suppliers and shall be applied concurrently. Recommended host board power supply filtering is shown in Figure 4 below. Vcc Rx, Vcc1 and Vcc Tx maybe internally connected within the QSFP+ transceiver module in any combination. The connector pins are each rated for a maximum current of 500mA.

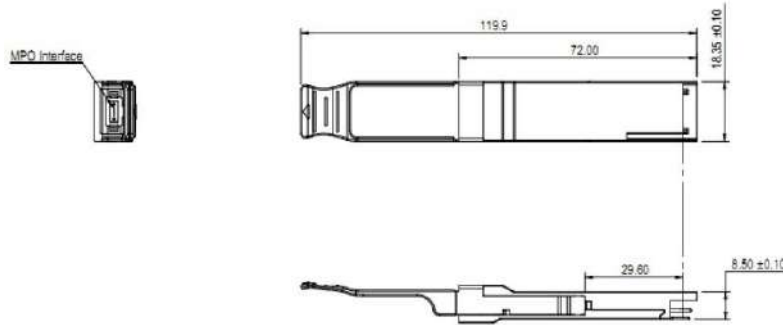

**Optical Receptacle Cleaning Recommendations:**

All fiber stubs inside the receptacle portions were cleaned before shipment. In the event of contamination of the optical ports, the recommended cleaning process is the use of forced nitrogen. If contamination is thought to have remained, the optical ports can be cleaned using a NTT international Cletop® stick type and HFE7100 cleaning fluid. Before the mating of patch-cord, the fiber end should be cleaned up by using Cletop® cleaning cassette.

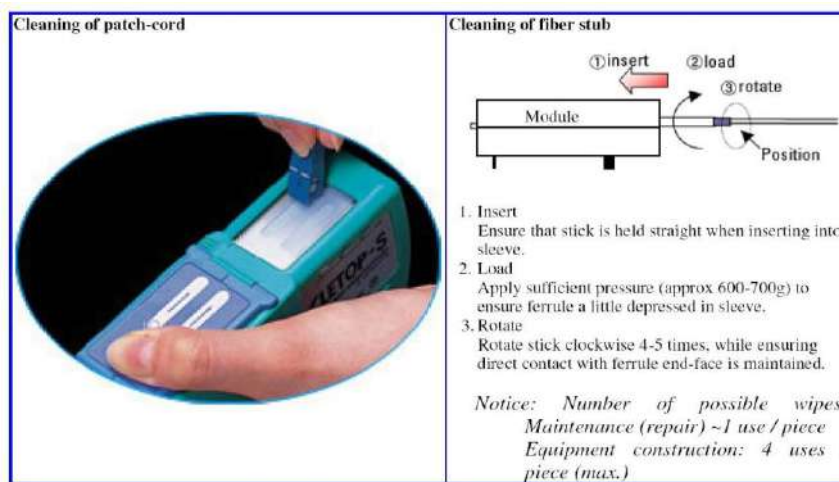

Note: The pictures were extracted from NTT-ME website. And the Cletop® is a trademark registered by NTT-ME

**Ordering Information**

Model Number	Part Number	Voltage	Temperature
AQSFP-40G-SR4,3	OPCS-MX3-85-CB	3.3V	0°C to 70 °C

Note: All information contained in this document is subject to change without notice.

**Copyright @ Alpha Bridge Technologies Private Limited**

This document is ABTPL Public Information. ABTPL reserves the right to alter, update and otherwise change the information contained in the document from time to time. [www.alphabridge.tech](http://www.alphabridge.tech)