

Chapter 37: ERPS



Contents

Chapter 37	ERPS	3
37.1	ERPS Overview	3
37.1.1	ERPS Basic Conception	3
37.1.2	ERPS Ring Protection Mechanism	6
37.2	Configure ERPS	8
37.2.1	ERPS Configuration List	8
37.2.2	Enable/Disable ERPS	9
37.2.3	Configure ERPS Instance	9
37.2.4	Configure Connectivity Detection of ERRP Link	10
37.2.5	Configure ERPS Related Timers	10
37.2.6	ERPS Display and Maintenance	11

Chapter 37 ERPS

37.1 ERPS Overview

ERPS (Ethernet Ring Protection Switching) is released by ITU-T with the convergence rate of telecommunication level. If all devices inside the ring support this agreement, it can achieve intercommunication.

37.1.1 ERPS Basic Conception

ERPS mainly includes ERPS ring, node, port role and port status.

1. *ERPS Example*

ERPS instance is formed by the same instance ID, control VLAN and interconnected GPON.

2. *Control VLAN*

Control VLAN is the transmission VLAN of ERPS protocol, and the protocol packet will carry corresponding VLAN tag.

3. *RPL*

RPL (Ring Protection Link), Link designated by mechanism that is blocked during Idle state to

prevent loop on Bridged ring

4. *ERPS ring*

ERPS ring is ERPS basic unit. It composed by a set of the same control VLAN and the interlinked L2 GPON equipment.

5. *Node*

The L2 GPON equipment added in ERPS ring are called nodes. Each node cannot be added to more than two ports in the same ERPS ring. The nodes are divided into RPL Owner, Neighbor, Next Neighbor, and Common.

6. *Port Role*

In ERPS, port roles include: RPL Owner, Neighbor, Next Neighbor, and Common:

RPL Owner: An ERPS ring has only one RPL Owner port configured by the user and it prevents loops in the ERPS ring via blocking the RPL Owner port. The node that owns the RPL Owner port becomes the RPL Owner node.

RPL Neighbour: An ERPS ring has only one RPL Neighbor port configured by the user and it must be a port connected to the RPL Owner port. If the network is normal, it will block together with the RPL Owner port to prevent loops in the ERPS ring. The node with the RPL Neighbor port becomes the RPL Neighbor node.

RPL Next Neighbour: An ERPS ring can have up to two RPL Next Neighbor ports configured by the user. It must be the port connecting the RPL Owner node or the RPL Neighbor node. To become the RPL Next Neighbor node, the RPL Next Neighbor port should own the node of RPL Next Neighbor port.

Note: RPL Next Neighbour nodes are not much different from ordinary nodes. They can be replaced by Common nodes.

Common: The common port. The ports except RPL owner, Neighbor and Neighbor port are common ports. If the node has only the Common port, this node will become the Common node.

7. Port Status

In the ERPS ring, the port status of the ERPS protocol is divided into three types.

Forwarding: In Forwarding status, the port forwards user traffic and receives / forwards R-APS packets. Moreover, it forwards R-APS packets from other nodes.

Discarding: In the Discarding status, the port can only receive / forward R-APS packets and cannot forward R-APS packets from other nodes.

Disable: port in Linkdown status.

8. Work Mode: ERPS operating mode

Work mode includes: revertive and non-revertive.

Revertive: When the link fails, the RPL link is in the release protection state and the RPL link is re-protected after the faulty link is restored to prevent loops.

Non-revertive: After the fault is rectified, the faulty node remains faulty (without entering Forwarding) and the RPL link remains in the release protection state.

37.1.2 ERPS Ring Protection Mechanism

ERPS uses ETH CFM for link monitoring. When the network is normal, a blocking link is set on the ring network to prevent the ring network from ringing. If a fault occurs in the network, a blocked backup link is opened to ensure uninterrupted link between each node. The general process is as follows:

As shown, when six devices are connected in a ring and the link is in the IDLE state, the loop is removed via setting the RPL link and locking the port (RPL Owner port).

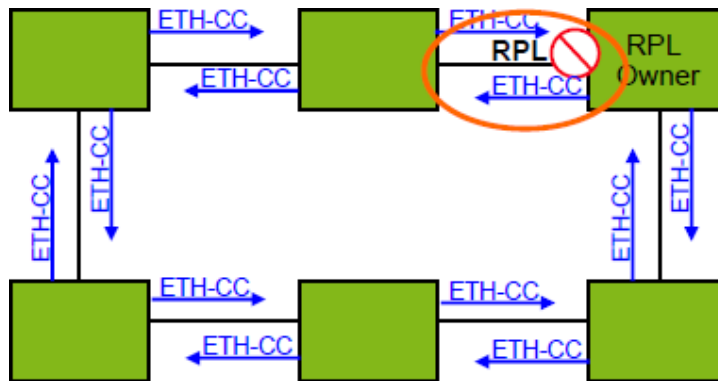

When a node on the link detects a fault, it immediately blocks the faulty node and reports the fault message (R-APS (SF)) to all the other devices in the ring. After receiving the message, all other nodes refresh the FDB. The RPL owner port receives the fault message, and the recovery port is in the forwarding state. The ERPS ring enters the protection state. As shown in the Figure:

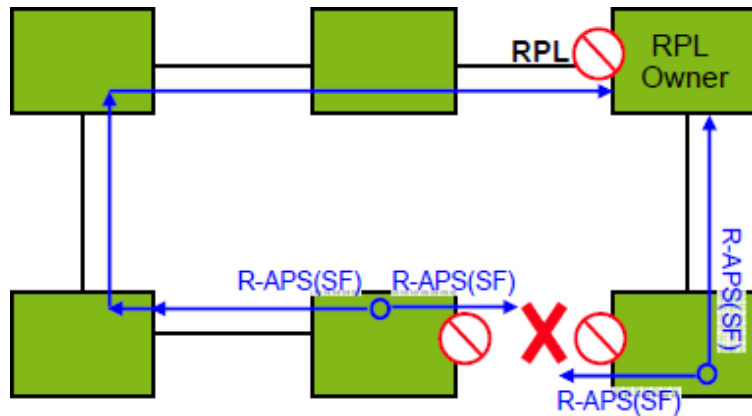

when the link of the faulty device recovers, it sends RAPS (NR) packets to other devices in the ring to inform them that there is no local request. When the RPL owner receives the packet, it will block the port and send the R-APS (NR, RB) message again after some time. After receiving the packet, the other nodes will refresh the FDB entry. Later, the port of the faulty node will be restored to the forwarding state, and the ring will revert to the IDLE state.

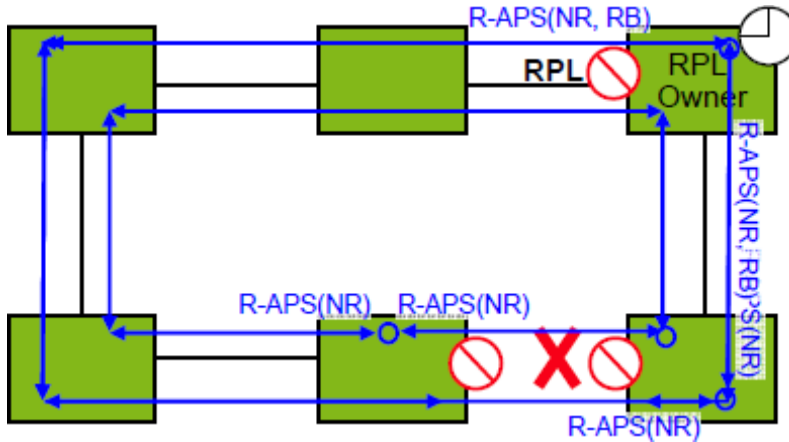

37.2 Configure ERPS

37.2.1 ERPS Configuration List

Configuration Task	Description	Detailed Configuration
Enable/Disable ERPS	Required	37.2.2
Configure ERPS Instance	Required	37.2.3
Configure Connectivity Detection of ERRP Link	Optional	37.2.4
Configure ERPS Related Timers	Optional	37.2.5
ERPS Display and Maintenance	Optional	37.2.6

37.2.2 Enable/Disable ERPS

Operation	Command	Remarks
Enter the global configuration mode	system-view	
Enable ERPS	erps	
Disable ERPS	undo erps	

37.2.3 Configure ERPS Instance

Operation	Command	Remarks
Enter the global configuration mode	system-view	
Configure erps instance	erps instance <i>instance-id</i>	
Configure control-vlan	control-vlan <i>vlan id</i>	
Configure work-mode	work-mode { revertive non-revertive }	
Configure ring id	ring <i>ring id</i>	
Configure ring level	ring level	
Configure ring port role	{ port0 port1 } ethernet <i>interface-num</i> [neighbor next-neighbour owner]	
Configure protected-instance	protected-instance <i>inst-list</i>	
Enable/Disable ring	ring [enable disable]	

Note:

About Ring ID: ERPS ring ID, the last byte of the DMAC in the R-APS message is Ring Id. From G.8032 can be learned that the ERPS ring ID can be the same, and the control VLAN needs to be different. The reverse is also true. The ring ID of each instance can be 1 to 239, and the control VLAN does not allow duplication.

To configure ERPS port, you must disable the spanning tree.

37.2.4 Configure Connectivity Detection of ERRP Link

In ERPS, there is no HELLO packet to monitor link connectivity in real time. Instead, it uses the CC function in ETH CFM to detect the link connectivity by sending ETH-CC messages between the two ports. Therefore, you need to configure the CFM CC for the ports in the ERPS. In the ERRP instance, you need to configure the MEL (MEG level, which must be consistent with the CFM configuration).

For more information about CFM, please refer to the CFM User Manual.

Operation	Command	Remarks
Enter the global configuration mode	system-view	
Configure erps instance	erps instance <i>instance-id</i>	
Configure MEL	mel <i>level</i>	

37.2.5 Configure ERPS Related Timers

ERPS has two timers: WTR timer and Guard timer.

WTR timer: When the RPL owner port is restored to the Forwarding state due to another device or link failure, if the fault is restored and some ports may not have been changed from the Down state to the Up state, it starts the WTR timer when the RPL owner port receives the fault-free RAPS packet from a port to prevent the shock of blocking point; If the fault is received before the timer expires, the WTR timer is disabled. If a faulty RAPS packet from another port is received before the timer times out, the WTR timer will be disabled. If the WTR timer does not receive any faulty RAPS packets from other ports, it will block the RPL Owner

port and send RPL blocking RAPS packets after timed out. After receiving the packet, the other ports set the forwarding state of its own port as Forwarding state.

Guard timer: After the failure recovery, the equipment involved in link failure or node failure will send R-APS packet to the other devices and it will start the Guard Timer at the same time. The device does not process RAPS packets until the timer times out with the purpose to prevent the receipt of outdated faulty R-APS packets. If the device receives the faulty RAPS packet from another port after the timer times out, the port forwarding state will turn to Forwarding.

Operation	Command	Remarks
Enter the global configuration mode	system-view	
Configure erps instance	erps instance <i>instance-id</i>	
Configure wtr-timer	wtr-timer <i>timer value</i>	
Configure guard-timer	guard-timer <i>timer value</i>	

37.2.6 ERPS Display and Maintenance

Operation	Command	Remarks
Display ERPS information	display erps [instance <i>instance id</i>]	
Display control-vlan	display erps control-vlan [<i>vid</i>]	
Display the sending and receiving packets	display erps [instance <i>instance id</i>] statistics	
Display the sending and receiving packets	clear erps [instance <i>instance id</i>] statistics	