

+

**Alpha Bridge
ASFPP-10G-SR
Datasheet**

ASFPP-10G-SR Datasheet

+



Features

- Optical interface compliant to IEEE 802.3ae 10GBASE-SR
- Electrical interface compliant to SFF-8431
- Hot Pluggable
- 850nm VCSEL transmitter, PIN photo-detector
- Maximum link length of 300m on 2000MHz/km MMF
- Operating case temperature: 0 to 70 °C
- Low power consumption
- Maximum link length of 300m on 2000MHz/km MMF
- All-metal housing for superior EMI performance
- Advanced firmware allows customer system encryption information to be stored in the transceiver
- Cost effective SFP+ solution, enables higher port densities and greater bandwidth
- RoHS6 compliant (lead-free)

Applications

- 10GBASE-SR at 10.3125Gbps
- 10GBASE-SW at 9.953Gbps
- Other optical links

Description

This SFP+ SR module electrical interface is compliant to SFI electrical specifications. The transmitter input and receiver output impedance is 100 Ohms differential. Data lines are internally AC coupled. The module provides differential termination and reduce differential to common mode conversion for quality signal termination and low EMI. SFI typically operates over 200 mm of improved FR4 material or up to about 150mm of standard FR4 with one connector.

Absolute Maximum Ratings

Parameter	Symbol	Min.	Typ.	Max.	Units	Notes
Storage Temperature	T_c	-40		85	°C	
Operating Case Temperature	T_c	0		70	°C	
Power Supply Voltage	VCC	0		3.6	V	
Relative Humidity	RH	5		95	%	
RX Input Average Power	$P_{max\ ICC}$			0	dBm	

Recommended Operating Conditions

Parameter	Symbol	Min.	Typ.	Max.	Units	Note
Power Supply Voltage	VCC	3.14	3.3	3.465	V	
Operating Case Temperature	T_C	0	25	70	°C	

Digital Diagnostics Functions

Parameter	Symbol	Accuracy	Unit	Notes
Temperature monitor absolute error	DMI_Temp	± 3	oC	
Supply voltage monitor absolute error	DMI_VCC	±0.1	V	
TX power	DMI_TX	± 3 dB	dB	
RX power	DMI_RX	± 3 dB	dB	
Bias Current monitor	DMI_Ibias	± 10%	mA	

Optical Characteristics

Parameter	Symbol	Min.	Typ.	Max.	Units	Note
Transmitter						
Center Wavelength	λ_t	840	850	860	nm	
RMS spectral width	P_m	-	-	Note 1	nm	
Average Optical Power	P_{avg}	-6.5	-	-1	dBm	2
Extinction Ratio	ER	3.5	-	-	dB	3
Transmitter Dispersion Penalty	TDP	-	-	3.9	dB	
Relative Intensity Noise	R_{in}	-	-	-128	dB/Hz	12dB reflection
Optical Return Loss Tolerance		-	-	12	dB	
Receiver						
Center Wavelength	λ_r	840	850	860	nm	
Receiver Sensitivity	P_{sens}	-	-	-11.1	dBm	4
Stressed Sensitivity in OMA		-	-	-7.5	dBm	4
Los function	Los	-30	-	-12	dBm	
Overload	P_{in}	-	-	-1.0	dBm	4
Receiver Reflectance		-	-	-12	dB	

Notes:

- Trade-offs are available between spectral width, center wavelength and minimum OMA, as shown in table 6.
- The optical power is launched into MMF
- Measured with a PRBS 231-1 test pattern @10.3125Gbps
- Measured with a PRBS 231-1 test pattern @10.3125Gbps, BER≤10⁻¹²

Electro Characteristics

Parameter	Symbol	Min.	Typ.	Max.	Units	Note
Data Rate		-	10.3125	-	Gbps	
Power Consumption		-	1200	1500	mV	
Transmitter						
Single Ended Output Voltage Tolerance		-0.3	-4.0	4.0	V	
C common mode voltage tolerance		15	--		mV	
Tx Input Diff Voltage	V_I	180		700	mV	
Tx Fault	V_{oL}	-0.3		0.4	V	At 0.7mA
Data Dependent Input Jitter	DDJ			0.10	UI	
Data Input Total Jitter	TJ			0.28	UI	
Receiver						
Single Ended Output Voltage Tolerance		-0.3	-	4.0	V	
Rx Output Diff Voltage	V_o	300		850	mV	
Rx Output Rise and Fall Time (20% to 80%)	T_r/T_f	30			ps	20% to 80%
Total Jitter	TJ			0.70	UI	
Deterministic Jitter	DJ			0.42	UI	

Block Diagram of Transceiver

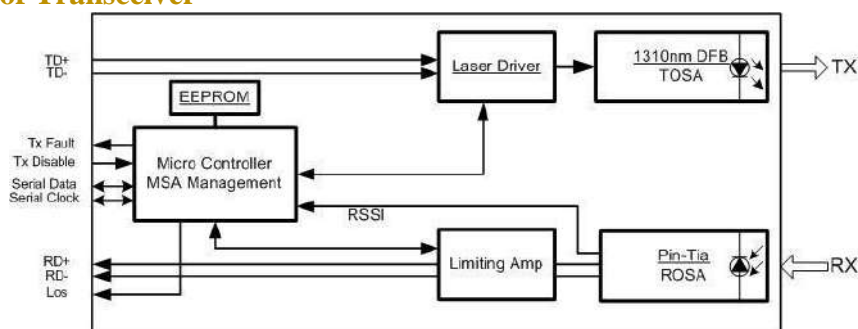

Pin Descriptions

Pin	Symbol	Function/Description	Notes
1	VEET	Transmitter Ground	1
2	Tx_FAULT	Transmitter Fault	2
3	Tx_DIS	Transmitter Disable. Laser output disabled on high or open	3
4	SDA	2-wire Serial Interface Data Line	2
5	SCL	2-wire Serial Interface Clock Line	2
6	MOD_ABS	Module Absent. Grounded within the module	4
7	RS0	Rate Select 0	5
8	RX_LOS	Loss of Signal indication. Logic 0 indicates normal operation	2
9	RS1	Rate Select 1	5
10	VEER	Receiver Ground	1
11	VEER	Receiver Ground	1
12	RD-	Receiver Inverted DATA out. AC Coupled	
13	RD+	Receiver DATA out. AC Coupled	
14	VEER	Receiver Ground	1
15	VCCR	Receiver Power Supply	
16	VCCT	Transmitter Power Supply	
17	VEET	Transmitter Ground	1
18	TD+	Transmitter DATA in. AC Coupled	
19	TD-	Transmitter Inverted DATA in. AC Coupled	
20	VEET	Transmitter Ground	1

Notes:

1. Module circuit ground is isolated from module chassis ground within the module.
2. should be pulled up with 4.7k – 10k ohms on host board to a voltage between 3.15V and 3.6V.
3. Tx_Disable is an input contact with a 4.7 kΩ to 10 kΩ pullup to VccT inside the module.
4. Mod_ABS is connected to VeeT or VeeR in the SFP+ module. The host may pull this contact up to Vcc_Host with a resistor in the range 4.7 kΩ to 10 kΩ. Mod_ABS is asserted “High” when the SFP+ module is physically absent from a host slot.
5. RS0 and RS1 are module inputs and are pulled low to VeeT with > 30 kΩ resistors in the module.

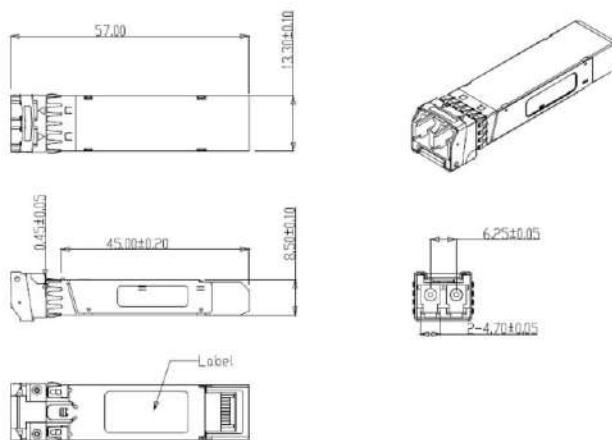
Dimensions

Optical Receptacle Cleaning Recommendations:

All fiber stubs inside the receptacle portions were cleaned before shipment. In the event of contamination of the optical ports, the recommended cleaning process is the use of forced nitrogen. If contamination is thought to have remained, the optical ports can be cleaned using a NTT international Cletop® stick type and HFE7100 cleaning fluid. Before the mating of patch-cord, the fiber end should be cleaned up by using Cletop® cleaning cassette.

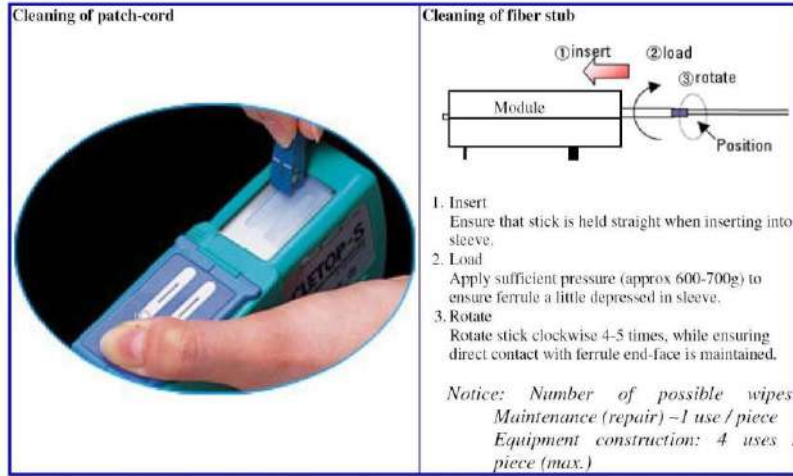

Note: The pictures were extracted from NTT-ME website. And the Cletop® is a trademark registered by NTT-ME

Ordering Information

Model Number	Part Number	Wavelength	Temperature
ASFPP-10G-SR	OPAT-MX3-85-CB	850nm	0°C to 70 °C

Note: All information contained in this document is subject to change without notice.

Copyright @ Alpha Bridge Technologies Private Limited

This document is ABTPL Public Information. ABTPL reserves the right to alter, update, and otherwise change the information contained in the document from time to time. www.alphabridge.tech