

Alpha Bridge
ASFPP-10G-ER33B
Datasheet





Features

- Support 9.95Gb/s to 10.3Gb/s data rates
- Simplex LC Connector Bi-Directional SFP+ Optical Transceiver
- Single 3.3V Supply
- Up to 40km on 9/125um SMF
- 1330nm DFB Laser transmitter, 1270nm receiver
- SFP+ MSA SFF-8431 Compliant
- Digital Diagnostic SFF-8472 Compliant
- RoHS compliant and Lead-Free
- Operating case temperature: 0°C ~70°C

Applications

- 10GBASE-ER at 10.3125Gbps
- 10GBASE-EW at 9.953Gbps
- Other Optical Links

Description

The SFP+ BWDM series single mode transceiver is a small form factor pluggable module for duplex optical data communications such as 10GBASE-ER/EW defined by IEEE 802.3ae. It is with the SFP+ 20-pin connector to allow hot plug capability.

The SFP+ BWDM module is designed for single-mode fiber and operates at a nominal wavelength of 1330nm; The transmitter section uses a multiple quantum well DFB, which is class 1 laser compliant according to International Safety Standard IEC-60825. The receiver section uses an integrated InGaAs detector (IDP) mounted in an optical header and a limiting post-amplifier IC

Absolute Maximum Ratings

Parameters	Symbol	Min.	Max.	Units
Supply Voltage	VCC	-0.5	3.6	V
Storage Temperature	Tc	-40	85	°C
Operating Case Temperature	Tc	0	70	°C
Relative Humidity	RH	0	85	%

Recommended Operating Conditions

Parameter	Symbol	Min.	Typ.	Max.	Units
Supply Voltage	VCC	3	3.3	3.6	V
Supply Current	Icc		300	450	mA
Operating Case Temperature	TC	0	25	70	°C
Module Power Dissipation	Pm	-	1	1.5	W

Notes:

1. Supply current is shared between VCCTX and VCCR X
2. In-rush is defined as current level above steady state current requirements.

Diagnostics

Parameters	Symbol	Accuracy	Unit	Notes
Temperature monitor absolute error	DMI_Temp	± 3	°C	
Supply voltage monitor absolute error	DMI_VCC	±0.3	V	
TX power	DMI_TX	± 3 dB	dBm	
RX power	DMI_RX	± 3 dB	dBm	
Bias Current monitor	DMI_Ibias	± 10%	mA	

Optical Characteristics

Parameter	Symbol	Min.	Typ.	Max.	Units	Notes
Transmitter						
Optical Wavelength	λ_C	1320	1330	1340	nm	
Side Mode Suppression Ratio	<i>SMSR</i>	30			dB	
Spectral Width (-20dB)	$\Delta\lambda$			1	nm	
Average Output Power	<i>Pop</i>	1		5	dBm	1
Extinction Ratio	<i>ER</i>	3.5			dB	
Eye Mask	<i>Compliant with IEEE 802.3</i>					
Transmitter Dispersion Penalty	<i>TDP</i>			3.2	dB	
Launch Power of OFF Transmitter	<i>POUT_OFF</i>			-30	dBm	
Relative Intensity Noise	<i>RIN</i>			-128	dB/Hz	
Receiver						
Center wavelength	λ_C	1260	1270	1280	nm	
Average Receiver Power	<i>PSENS</i>			-15	dBm	1,2
Receiver Overload	<i>PMAX</i>			0.5	dBm	
LOS Assert	<i>LOSA</i>	-30			dBm	
LOS De-assert	<i>LOSD</i>			-15	dBm	
LOS Hysteresis	<i>LOSH</i>	0.5			dB	

Note:

1. Average Receiver Power (Min) is informative and not the principal indicator of signal strength. A received power below this value cannot be compliant.
2. Measured with a PRBS2³¹-1 test pattern @10.3125Gbps, BER \leq 10⁻¹²

Electrical Characteristics

Parameter	Symbol	Min.	Typ.	Max.	Units	Note
Transmitter						
Input differential impedance	<i>RIN</i>		100		Ω	2
Single-ended data input swing	<i>Vin_PP</i>	150		1200	mVpp	
Transmit Disable Voltage	<i>VD</i>	2		Vcc	V	
Transmit Enable Voltage	<i>VEN</i>	VEE		VEE+0.8	V	3
Receiver						
Output Differential impedance	<i>Rout</i>		100		Ω	2
Single-Ended Data Output Swing	<i>VOUt_PP</i>	300		700	mV	4
LOS Fault	VLOS fault	2		VCCHOST	V	5
LOS Normal	VLOS norm	VEE		VEE+0.8	V	5

Notes:

1. Module power consumption never exceeds 1W..
2. AC coupled.
3. Or open circuit.
4. Into 100-ohm differential termination.
5. LOS is LVTTTL. Logic 0 indicates normal operation; logic1 indicates no signal detected.

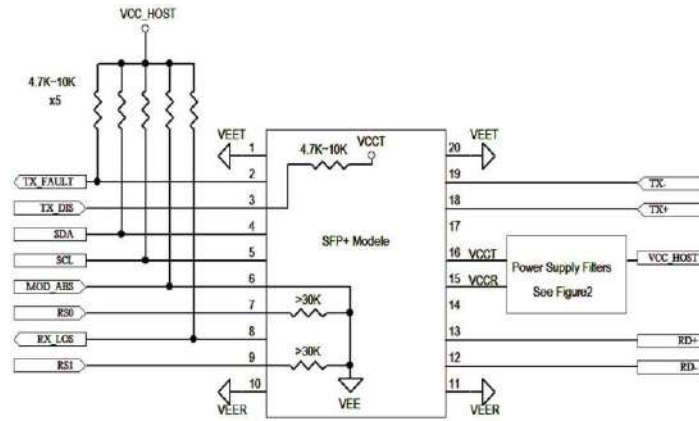

Pin Descriptions

Pin	Name	Description	Notes
1	VEET	Transmitter ground (common with receiver ground)	1
2	TX_FAULT	Transmitter Fault	2
3	TX_DISABLE	Transmitter Disable. Laser output disabled on high or open	3
4	SDA	2-wire Serial Interface Data Line	4
5	SCL	2-wire Serial Interface Clock Line	4
6	MOD_ABS	Module Absent. Grounded within the module	4
7	RS0	No connection required	
8	LOS	Loss of Signal indication. Logic 0 indicates normal operation	5
9	RS1	No connection required	1
10	VEER	Receiver ground (common with transmitter ground)	1
11	VEER	Receiver ground (common with transmitter ground)	1
12	RD-	Receiver Inverted DATA out. AC coupled	
13	RD+	Receiver Non-inverted DATA out. AC coupled	
14	VEER	Receiver ground (common with transmitter ground)	1
15	VCCR	Receiver power supply	
16	VCCT	Transmitter power supply	
17	VEET	Transmitter ground (common with receiver ground)	1
18	TD+	Transmitter Non-Inverted DATA in. AC coupled	
19	TD-	Transmitter Inverted DATA in. AC coupled	
20	VEET	Transmitter ground (common with receiver ground)	1

Notes:

- Module circuit ground is isolated from module chassis ground within the module.
- should be pulled up with 4.7k – 10k ohms on host board to a voltage between 3.15V and 3.6V.
- TX Disable is an input contact with a 4.7k~10kΩ pullup to VccT inside the module.
- Mod_ABS is connected to VeeT or VeeR in the SFP+ module. The host may pull this contact up to Vcc_Host with a resistor in the range 4.7 kΩ to 10 kΩ. Mod_ABS is asserted “High” when the SFP+ module is physically absent from a host slot.
- RS0 and RS1 are module inputs and are pulled low to VeeT with > 30 kΩ resistors in the module.

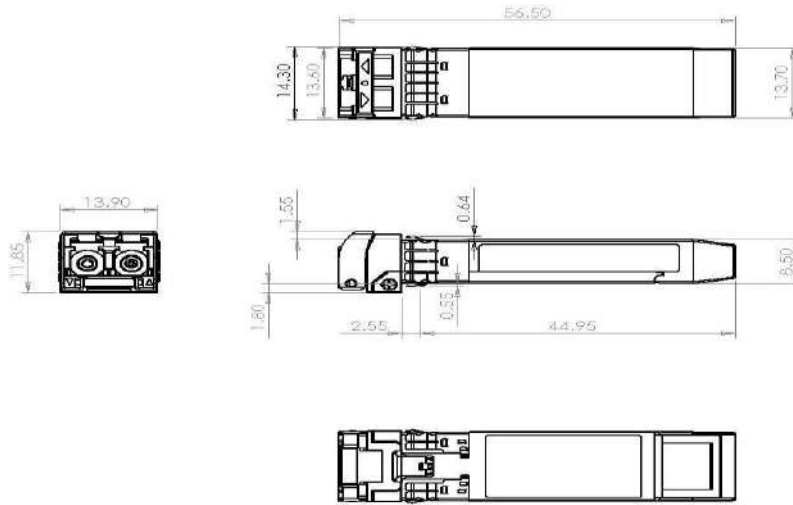

Optical Receptacle Cleaning Recommendations:

All fiber stubs inside the receptacle portions were cleaned before shipment. In the event of contamination of the optical ports, the recommended cleaning process is the use of forced nitrogen. If contamination is thought to have remained, the optical ports can be cleaned using a NTT international Cletop® stick type and HFE7100 cleaning fluid. Before the mating of patch-cord, the fiber end should be cleaned up by using Cletop® cleaning cassette

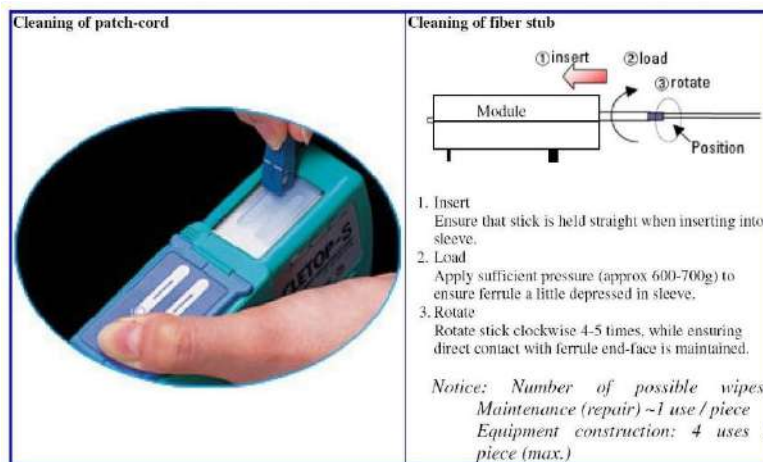

Note: The pictures were extracted from NTT-ME website. And the Cletop® is a trademark registered by NTT-ME

Ordering Information

Model Number	Part Number	Reach	Input/Output	TX/RX	SignalDetect	Voltage	Temperature
ASFPP-10G-ER33B	OPAK-W40-33-CF	40 km	AC/AC	1330/1270	TTL	3.3V	0°C to 70 °C
ASFPP-10G-ER33B-I	OPAK-W40-33-CF	40 km	AC/AC	1330/1270	TTL	3.3V	-40°C to 85 °

Note: All information contained in this document is subject to change without notice.