

**Alpha Bridge
ASFP-1G-eLX3149B
Datasheet**

Features

- SFP Multi-Source Agreement compliant
- Compliant with IEEE802.3z Gigabit Ethernet Standard
- Compliant with Fiber Channel 100-SM-LC-L standard
- Industry standard small form pluggable(SFP) package
- Simplex LC connector
- Differential LVPECL inputs and outputs
- Single power supply 3.3V
- TTL signal detect indicator
- Hot Pluggable
- Class 1 laser product complies with EN 60825-1
- RoHS Compliant

Absolute Maximum Ratings

Parameter	Symbol	Min.	Max.	Units	Note
Storage Temperature	TS	-40	85	°C	
Supply Voltage	Vcc	-0.5	4	V	
Input Voltage	VIN	-0.5	Vcc	V	
Output Current	Io	---	50	mA	
Operating Current	IOP	---	400	mA	

Recommended Operating Conditions

Parameter	Symbol	Min.	Max.	Units	Notes
Operating Case Temperature	TC	0	70	°C	OP6C-W20-B4-C
		-40	85	°C	OP6C-W20-B4-I
Power Supply Voltage	VCC	3.1	3.5	V	
Power Supply Current	I _{tx+IRX}		250	mA	

Transmitter Electro-optical Characteristics

Parameter	Symbol	Min.	Typ.	Max.	Units	Notes
Output Optical Power 9/125 μm fiber	P _{out}	-8	---	-2	dBm	Average
Extinction Ratio	ER	9	---	---	dB	
Center Wavelength	λ _c	1270	1310	1355	nm	
Spectral Width (RMS)	λ	---	---	2.5	nm	
Rise/Fall Time (20-80%)	T _{r, f}	---	---	260	ps	
Relative Intensity Noise	RIN	---	---	-120	dB/Hz	
Total Jitter	TJ	---	---	227	ps	
Output Eye	Compliant with IEEE802.3z					
Max P _{out} TX-DISABLE Asserted	POFF	---	---	-45	dBm	
Differential Input Voltage	V _{DIFF}	0.4	---	2	V	

Receiver Electro-optical Characteristics

V_{cc} = 3.1 V to 3.5 V, T_c = 0 °C to 70 °C (-40 °C to 85 °C)

Parameter	Symbol	Min.	Typ.	Max.	Units	Note
Optical Input Power-maximum	PIN	-1	---	---	dBm	BER < 10 ⁻¹²
Optical Input Power-minimum	PIN	---	---	-23	dBm	BER < 10 ⁻¹²
Operating Center Wavelength	λC	1480	---	1500	nm	
Optical Return Loss	ORL	14	---	---	dB	λ=1480~1500nm
Optical isolation	ISO	---	---	-40	dB	λ=1260~1360nm
Loss of signal-Asserted	PA	---	---	-23	dBm	
Loss of signal-Deasserted	PD	-35	---	---	dBm	
Differential Output Voltage	VDIFF	0.5	---	1.2	V	
Data Output Rise, Fall Time	T _{r, f}	---	---	0.35	ns	
Receiver Loss of Signal Output	RX_LOSL	0	---	0.5	V	
Receiver Loss of Signal Output	RX_LOSH	2.4	---	V _{cc}	V	

Block Diagram of Transceiver

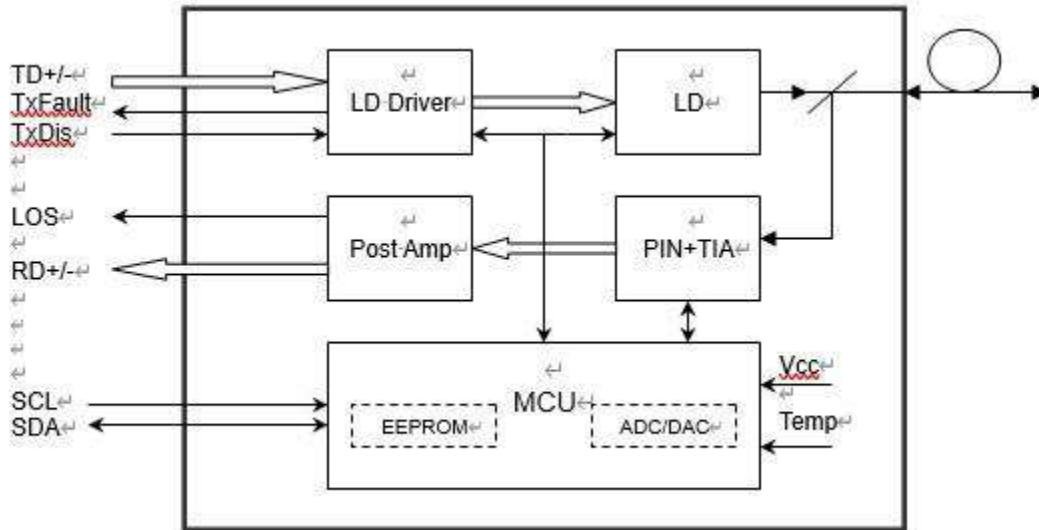

Transmitter and Receiver Optical Sub-assembly Section

A 1310 nm InGaAsP laser and an InGaAs PIN photodiode integrate with an WDM filter to form a bi-directional single fiber optical subassembly (OSA). The laser of OSA is driven by a LD driver IC which converts differential input LVPECL logic signals into an analog laser driving current. And, The photodiode of OSA is connected to a circuit providing post-amplification quantization, and optical signal detection.

TX_DISABLE

The TX_DISABLE signal is high (TTL logic “1”) to turn off the laser output.

Receive Loss (RX_LOS)

The RX_LOS is high (logic “1”) when there is no incoming light from the companion transceiver. This signal is normally used by the system for the diagnostic purpose. The signal is operated in TTL level.

Pin Assignment

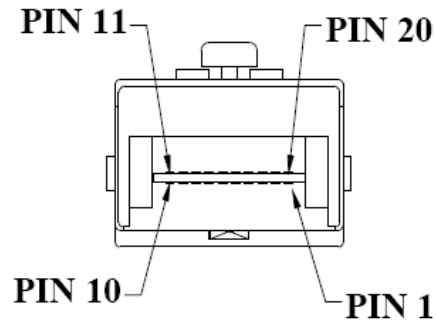

Pin Descriptions

<i>Pin</i>	<i>Signal Name</i>	<i>Description</i>
1	TGND	Transmitter Ground
2	TX_FAULT	Transmit Fault
3	TX_DISABLE	Transmit Disable
4	MOD_DEF(2)	SDA Serial Data Signal
5	MOD_DEF(1)	SCL Serial Clock Signal
6	MOD_DEF(0)	TTL Low
7	RATE SELECT	Open Circuit
8	RX_LOS	Receiver Loss of Signal, TTL High, Open collector
9	RGND	Receiver Ground
10	RGND	Receiver Ground
11	RGND	Receiver Ground
12	RX-	Receive Data Bar, Differential PECL, ac coupled
13	RX+	Receive Data, Differential PECL, ac coupled
14	RGND	Receiver Ground
15	VCCR	Receiver Power Supply
16	VCCT	Transmitter Power Supply
17	TGND	Transmitter Ground
18	TX+	Transmit Data, Differential PECL, ac coupled
19	TX-	Transmit Data Bar, Differential PECL, ac coupled
20	TGND	Transmitter Ground

Dimensions

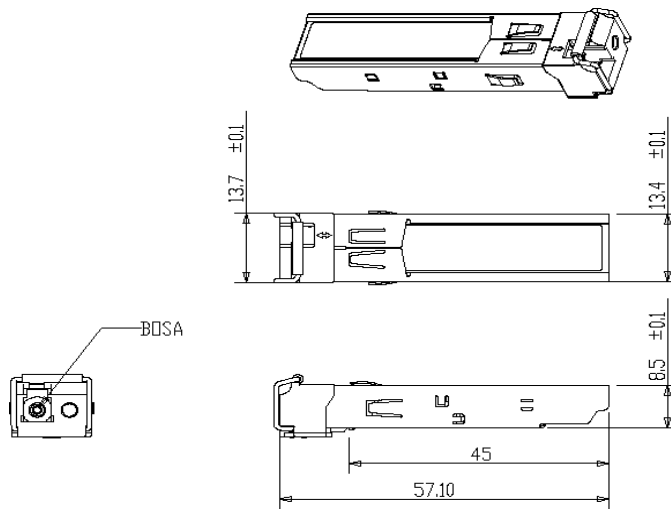

Optical Receptacle Cleaning Recommendations :

All fiber stubs inside the receptacle portions were cleaned before shipment. In the event of contamination of the optical ports, the recommended cleaning process is the use of forced nitrogen. If contamination is thought to have remained, the optical ports can be cleaned using a NTT international Cletop[®] stick type and HFE7100 cleaning fluid. Before the mating of patch-cord, the fiber end should be cleaned up by using Cletop[®] cleaning cassette.

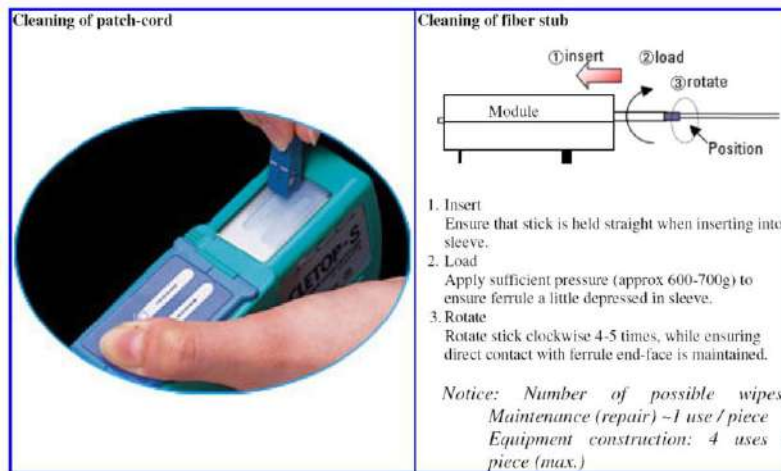

Note: The pictures were extracted from NTT-ME website. And the Cletop[®] is a trademark registered by NTT-ME

Ordering Information

Model Number	Part Number	Reach	TX/RX	Input/Out	Signal Detect	Temperature	LD Type
ASFP-1G-eLX3149B	OP6C-W20-B4-C	20 km	1310/1490	AC/AC	TTL	0°C to 70 °C	1310 FP
ASFP-1G-eLX3149B-I	OP6C-W20-B4-I	20 km	1310/1490	AC/AC	TTL	-40°C to 85 °C	1310 FP

Note: All information contained in this document is subject to change without notice.

Copyright @ Alpha Bridge Technologies Private Limited

This document is ABTPL Public Information. ABTPL reserves the right to alter, update, and otherwise change the information contained in the document from time to time. www.alphabridge.tech