

**Alpha Bridge
ASFP-1G-T
Datasheet**





Features

- Compliant with IEEE 802.3ab/ Gigabit Ethernet Standard
- Compliant with SFP MSA specifications.
- Hot-pluggable SFP footprint
- 10/100/1000BASE-T operation in the host system with SGMII interface
- EEPROM with Serial ID functionality
- Hot-pluggable capability
- Compliant with industry standard RFT electrical connector and cage
- Internal PHY IC is configurable by host system software via SFP 2-wire interface
- Support MDIX
- Compliant with RoHS

Applications

- Gigabit Ethernet over copper.
- Switch to switch interface.
- Switched backplane applications.
- File server interface

Performance

- ASFP-1G-T data link up to 100 m on standard CAT5 UTP

Absolute Maximum Ratings

Parameter	Symbol	Min.	Max.	Units	Note
storage Temperature	Ts	-40	85	°C	
Supply Voltage	VCC	0	5	V	

Recommended Operating Conditions

Parameter	Symbol	Min.	Max.	Units	Note
Operating Temperature	Tc	0	70	°C	
Supply Voltage	VCC	3.135	3.465	V	

Electrical Characteristics

V_{CC}=3.135 V to 3.465 V, T_c=0 °C to 70 °C

Parameter	Symbol	Min.	Typ.	Max.	Units	Note
Supply Current	ICC	---	350	400	mA	
Transmitter						
Data Input Differential Voltage	VD,TX	0.5	---	2.4	V	1
Differential Input Impedance	ZTX	80	100	120	Ohm	
Transmitter Disable Input-High	VDIS H	2.0	---	VCC+0.3	V	
Transmitter Disable Input-Low	VDIS L	0	---	0.8	V	
Receiver						
Data Output Differential Voltage	VD,R X	0.35	---	2	mV	3
Differential Output Impedance	ZRX	80	100	120	Ohm	
Data Output Rise/Fall Time	tr, R x / tf, Rx	---	180	---	Ps	4
LOS Output Voltage-High	VLO IS H	2	---	VCC+0.3	V	2
LOS Output Voltage -Low	VLO S L L	0	---	0.8	V	2

NOTES:

1. Internally AC coupled and terminated to 100-Ohm differential load.
2. Pull up to V_{CC} with a 4.7K – 10K Ohm resistor on host Board
3. Internally AC coupled but requires a 100-Ohm differential termination at MAC side.
4. These are unfiltered 20%~80% values

Pin Assignment

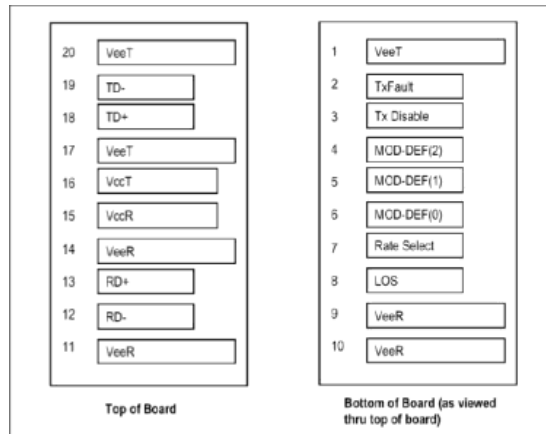

Pin Function Definitions

Pin	Name	Function	Plug	Notes
1	VeeT	Transmitter Ground	1	Note 5
2	TX Fault	Transmitter Fault Indication	3	Note 1 - Function not available
3	TX_Disable	Transmitter Disable	3	Note 2 - Module disables on high or open
4	MOD-DEF2	Module Definition 2	3	Note 3 - Two-wire serial ID interface
5	MOD-DEF1	Module Definition 1	3	Note 3 - Two-wire serial ID interface
6	MOD-DEF0	Module Definition 0	3	Note 3 - grounded in module
7	Rate Select	Not Connect	3	Function not available
8	LOS	Loss of Signal	3	Note 4 - Function not available
9	VeeR	Receiver Ground	1	Note 5
10	VeeR	Receiver Ground	1	Note 5
11	VeeR	Receiver Ground	1	Note 5
12	RD-	Inverse Received Data Out	3	Note 6
13	RD+	Received Data Out	3	Note 6
14	VeeR	Receiver Ground	1	Note 5
15	VccR	Receiver Power	2	Note 7 - 3.3V ± 5%
16	VccT	Transmitter Power	2	Note 7 - 3.3V ± 5%
17	VeeT	Transmitter Ground	1	Note 5
18	TD+	Transmitter Data In	3	Note 8
19	TD-	Inverse Transmitter Data In	3	Note 8
20	VeeT	Transmitter Ground	1	Note 5

Notes:

- TX Fault is not supported and tied to ground within the module.
- TX disable is an input that is used to reset the chip of Gigabit Ethernet PHY inside the copper SFP. It is pulled up within the module with a 4.7 – 10 K Ω resistor.
 Low (0 – 0.8V): PHY IC on
 (>0.8, < 2.0V): Undefined
 High (2.0 – 3.465V): PHY IC Disabled Open: PHY IC Disabled
- These are the module definition pins. They should be pulled up with a 4.7K – 10K Ω resistor on the host board. The pull-up voltage shall be VccT or VccR. MOD-DEF 0 is grounded in the module to indicate that the module is present. MOD-DEF 1 and MOD-DEF 2 are the clock and data lines of the two-wire serial interface, respectively.
- LOS (Loss of Signal) is not available and tied to ground within the module.
- VeeR and VeeT are internally connected within the copper SFP.
- RD+ and RD- are the received differential outputs, and they are AC-coupled 100~ differential lines that should be

terminated with 100 Ω (differential) at user's SERDES. The AC coupling is done inside the copper SFP and thus not required on the host board. The differential voltage swing will be between 250mV and 625 mV, while properly terminated.

- 7) VccR and VccT are the receiver and transmitter power supplies, and they are internally connected within the copper SFP. The power rail is defined as 3.3V \pm 5% at the SFP connector pin.
- 8) TD+ and TD- are the transmitted differential inputs, and they are terminated with 100 Ω differential load inside the module. The AC coupling is done inside the module, and thus not required on the host board.

Dimensions

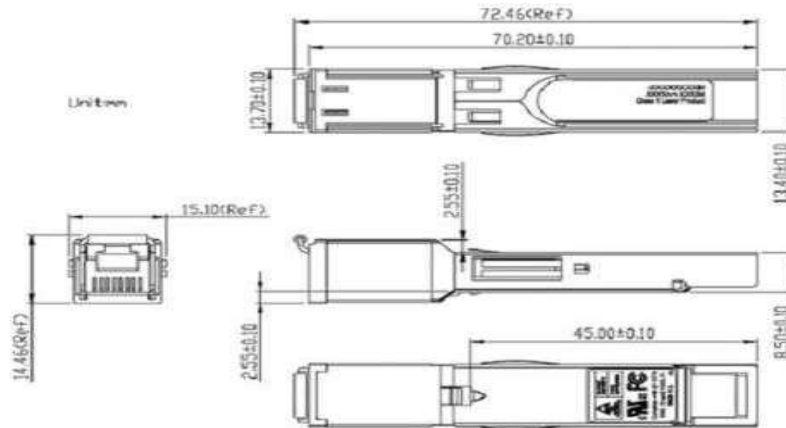

ASFP-1G-T EEPROM Serial ID Information

ASFP-1G-T Provides 128-byte EEPROM, which can be accessed via the 2-wire serial communication protocol per SFP MSA with a device address of 0xA0.

Address	Hex	ASCII	Address	Hex	ASCII	Address	Hex	ASCII	Address	Hex	ASCII	Address	Hex	Address	Hex	ASCII
0	3		25	68	h	50	30	0	75	SN		100	0	125	0	
1	4		26	20		51	2D	-	76	SN		101	0	126	0	
2	0		27	20		52	43	C	77	SN		102	0	127	0	Note 5
3	0		28	20		53	32	2	78	SN		103	0			
4	0		29	20		54	20		79	SN		104	0			
5	0		30	20		55	20		80	SN		105	0			
6	8		31	20		56	30	0	81	SN		106	0			
7	0		32	20		57	30	0	82	SN		107	0			
8	0		33	20		58	30	0	83	SN		108	0			
9	0		34	20		59	30	0	84	DC	Note 3	109	0			
10	0		35	20		60	0		85	DC		110	0			
11	1		36	0		61	0		86	DC		111	0			
12	0D		37	0		62	0		87	DC		112	0			
13	0		38	0		63	CS1	Note 1	88	DC		113	0			
14	0		39	0		64	0		89	DC		114	0			
15	0		40	4F	O	65	12		90	DC		115	0			
16	0		41	50	P	66	0		91	DC		116	0			
17	0		42	36	6	67	0		92	0		117	0			

18	64		43	43	C	68	SN	Note 2	93	0		118	0			
19	0		44	2D	-	69	SN		94	0		119	0			
20	4F	O	45	54	T	70	SN		95	CS2	Note 4	120	0			
21	70	p	46	58	X	71	SN		96	0		121	0			
22	74	t	47	31	1	72	SN		97	0		122	0			
23	65	e	48	2D	-	73	SN		98	0		123	0			
24	63	c	49	30	0	74	SN		99	0		124	0			

Notes:

- 1) Byte 63(CS1): Check sum of bytes 0-62.
- 2) Byte 68-83 (SN): Serial number.
- 3) Byte 84-91 (DC): Date code.
- 4) Byte 95 (CS2): Check sum of bytes 64-94.
- 5) Bytes 128-255 had been set hex. 00.

Ordering Information

<i>Model Number</i>	<i>Part Number</i>	<i>Distance</i>	<i>Voltage</i>	<i>Temperature</i>
ASFP-1G-T	OP6C-TX1-00-C1	100m	3.3V	0°C to 70 °C

Note: All information contained in this document is subject to change without notice.

Copyright @ Alpha Bridge Technologies Private Limited

This document is ABTPL Public Information. ABTPL reserves the right to alter, update and otherwise change the information contained in the document from time to time. www.alphabridge.tech