

Alpha Bridge
ASFP-1G-LX4931B
Datasheet



Features

- SFP Multi-Source Agreement compliant
- Compliant with IEEE802.3z Gigabit Ethernet Standard
- Compliant with Fiber Channel 100-SM-LC-L standard
- Industry standard small form pluggable (SFP) package
- Simplex LC connector
- Differential LVPECL inputs and outputs
- Single power supply 3.3V
- TTL signal detect indicator
- Hot Pluggable
- Class 1 laser product complies with EN 60825-1
- RoHS Compliant

Absolute Maximum Ratings

Parameter	Symbol	Min.	Max.	Units	Note
Storage Temperature	T_S	-40	85	°C	
Supply Voltage	V_{CC}	-0.5	4.0	V	
Input Voltage	V_{IN}	-0.5	V_{CC}	V	
Output Current	I_O	---	50	mA	
Operating Current	IOP	---	400	mA	

Recommended Operating Conditions

Parameter	Symbol	Min.	Max.	Units	Typical
Case Operating Temperature	T_C	0	70	°C	OP6C-W10-B9-C
		-40	85	°C	OP6C-W10-B9-I
Supply Voltage	V_{CC}	3.1	3.5	V	
Supply Current	ITX+IRX	--	300	mA	

Transmitter Electro-optical Characteristics

$V_{CC} = 3.1\text{ V to }3.5\text{ V}$, $T_C = 0\text{ °C to }70\text{ °C}$ ($-40\text{ °C to }85\text{ °C}$)

Parameter	Symbol	Min.	Typ.	Max.	Units	Note
Output Optical Power 9/125 μm fiber	P_{out}	-9	---	-3	dBm	Average
Extinction Ratio	ER	9	---	---	dB	
Center Wavelength	λ_C	1480	1490	1500	nm	
Spectral Width (-20dB)	λ	---	---	1	nm	
Side Mode Suppression Ratio	$SMSR$	30			dB	
Rise/Fall Time (20-80%)	$T_{r, f}$	---	---	260	ps	
Relative Intensity Noise	RIN	---	---	-120	dB/Hz	
Total Jitter	T_J	---	---	227	ps	
Output Eye	Compliant with IEEE802.3z					
Max P_{out} TX-DISABLE Asserted	$POFF$	---	---	-45	dBm	
Differential Input Voltage	V_{DIFF}	0.4	---	2	V	

Receiver Electro-optical Characteristics

V_{CC} = 3.1 V to 3.5 V, TC = 0 °C to 70 °C (-40 °C to 85 °C)

Parameter	Symbol	Min.	Typ.	Max.	Units	Note
Optical Input Power-maximum	PIN	-1	---	---	dBm	BER < 10 ⁻¹²
Optical Input Power-minimum	PIN	---	---	-21	dBm	BER < 10 ⁻¹²
Operating Center Wavelength	λ _C	1260	---	1360	nm	
Optical Return Loss	ORL	14	---	---	dB	λ=1260~1360nm
Optical isolation	ISO	---	---	-40	dB	λ=1480~1500nm
Loss of signal-Asserted	PA	---	---	-21	dBm	
Loss of signal-De asserted	PD	-35	---	---	dBm	
Differential Output Voltage	VDIFF	0.5	---	1.2	V	
Data Output Rise, Fall Time	T _{r, f}	---	---	0.35	ns	
Receiver Loss of Signal Output Voltage-Low	RX_LOSL	0	---	0.5	V	
Receiver Loss of Signal Output Voltage - High	RX_LOSH	2.4	---	V _{CC}	V	

Block Diagram of Transceiver

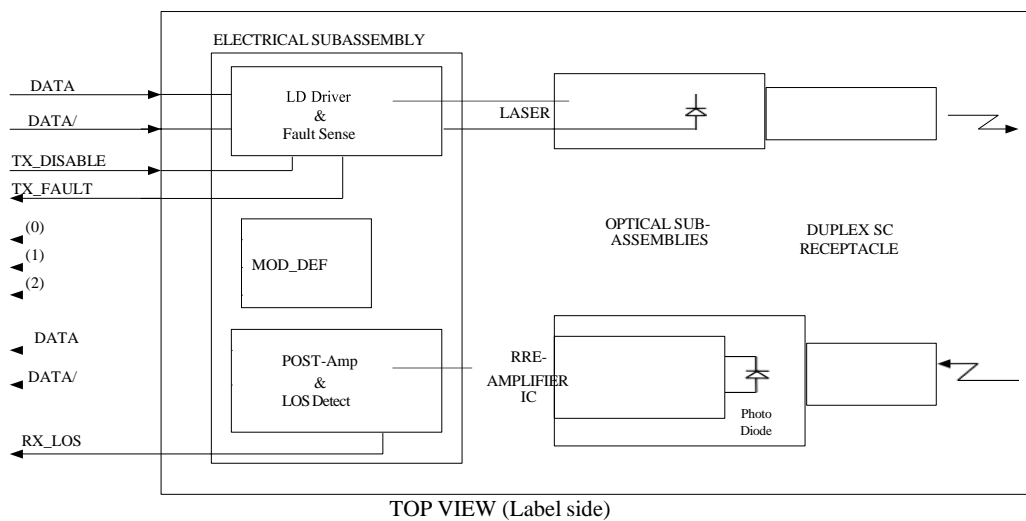

Transmitter and Receiver Optical Sub-assembly Section

A 1490 nm InGaAsP laser and an InGaAs PIN photodiode integrate with a WDM filter to form a bi-directional single fiber optical subassembly (OSA). The laser of OSA is driven by an LD driver IC which converts differential input LVPECL logic signals into an analog laser driving current. And, the photodiode of OSA is connected to a circuit providing post-amplification quantization, and optical signal detection.

TX_DISABLE

The TX_DISABLE signal is high (TTL logic “1”) to turn off the laser output.

Receive Loss (RX_LOS)

The RX_LOS is high (logic “1”) when there is no incoming light from the companion transceiver. This signal is normally used by the system for the diagnostic purpose. The signal is operated in TTL level.

Pin Assignment

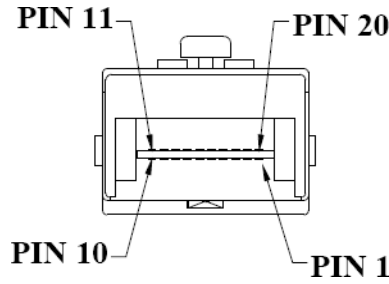

Pin Descriptions

Pin	Signal Name	Description
1	TGND	Transmitter Ground
2	TX_FAULT	Transmit Fault
3	TX_DISABLE	Transmit Disable
4	MOD_DEF (2)	SDA Serial Data Signal
5	MOD_DEF (1)	SCL Serial Clock Signal
6	MOD_DEF (0)	TTL Low
7	RATE SELECT	Open Circuit
8	RX_LOS	Receiver Loss of Signal, TTL High, Open collector
9	RGND	Receiver Ground
10	RGND	Receiver Ground
11	RGND	Receiver Ground
12	RX-	Receive Data Bar, Differential PECL, ac coupled
13	RX+	Receive Data, Differential PECL, ac coupled
14	RGND	Receiver Ground
15	VCCR	Receiver Power Supply
16	VCCT	Transmitter Power Supply
17	TGND	Transmitter Ground
18	TX+	Transmit Data, Differential PCEL, ac coupled
19	TX-	Transmit Data Bar, Differential PCEL, ac coupled
20	TGND	Transmitter Ground

Dimensions

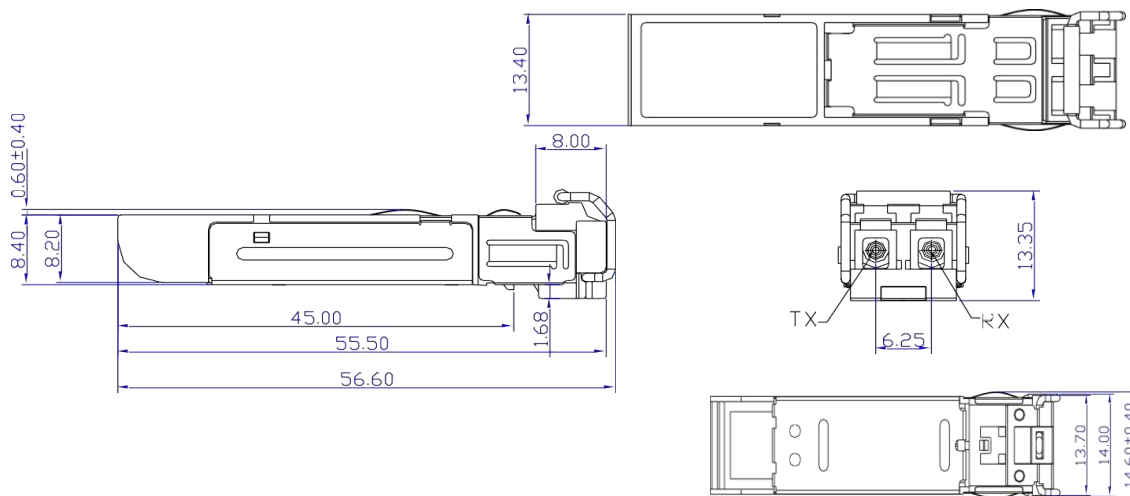

Ordering Information

<i>Model Number</i>	<i>Part Number</i>	<i>Reach</i>	<i>TX/RX</i>	<i>Input/Out</i>	<i>Signal Detect</i>	<i>Temperature</i>	<i>LD Type</i>
ASFP-1G-LX4931B	OP6C-W10-B9-C	10 km	1490/1310	AC/AC	TTL	0°C to 70 °C	1490 DFB
ASFP-1G-LX4931B-I	OP6C-W10-B9-I	10 km	1490/1310	AC/AC	TTL	-40°C to 85 °C	1490 DFB

Note: All information contained in this document is subject to change without notice