

Alpha Bridge
ASFP-10G-ER15
Datasheet



Features

- Compliant with SFF-8431, SFF-8432 and IEEE802.3ae
- 10GBASE-ER and 2G/4G/8G/10G Fiber Channel applications
- Cooled EML Transmitter and PIN receiver
- Link Length up to 40km
- Low Power Dissipation 1.5W Maximum
- Single 3.3V power supply
- RoHS6 compliant (lead-free)
- Operating case temperature: -5°C ~70°C

Applications

- 10GBASE-ER (with/without FEC)
- 10G Fiber Channel (with/without FEC)

Description

This SFP+ ER 1550 transceiver is a “Limiting Module”, designed for 10GBASE-ER and 2G/4G/8G/10G Fiber Channel applications. The Transceiver has two sections: the transmitter section incorporates a cold EML laser. The receiver section consists of a PIN photodiode integrated with a TIA. All modules satisfy class I laser safety requirements. Digital Diagnostics Functions are available via a 2-wire serial interface, as specified in SF-8472, which allows real-time access to device operating parameters such as transceiver temperature, laser bias current, transmitted optical power, received optical power, and transceiver supply voltage.

Absolute Maximum Ratings

Parameter	Symbol	Min.	Typ.	Max.	Units	Note
Power Supply Voltage	V _{cc}	0.5		3.8	V	
Storage Temperature	T _c	-40		85	°C	
Relative Humidity	RH	0		85	%	

Recommended Operating Conditions

Parameter	Symbol	Min	Typ.	Max	Units
Operating Case Temperature	T _c	-5		70	°C
Power Supply Voltage	V _{cc}	3.135	3.3	3.465	V
Supply Current	I _{cc}		360	450	mA
Module Power Dissipation	P _m		1.2	1.5	W

Digital Diagnostic Functions

Parameter	Symbol	Accuracy	Unit	Notes
Temperature Monitor Absolute Error	DMI_Temp	± 3	oC	Over operating Temp
Supply Voltage Monitor Absolute Error	DMI_VCC	±0.08	V	Full operating range
RX Power Monitor Absolute Error	DMI_RX	± 3 dB	dB	1
Bias Current Monitor	DMI_Ibias	± 10%	mA	
Laser Power Monitor Absolute Error	DMI_TX	± 3 dB	dB	1

Notes:

1. Due to the measurement accuracy of different single-mode fibers, there could be an additional +/-1 dB fluctuation or a +/-3 dB total accuracy.

Optical Characteristics

Parameter	Symbol	Min.	Typ.	Max.	Units	Note
Transmitter						
Center Wavelength	λ_t	1530		1530	nm	
Average Optical Power	P _o	-3.8		3	dBm	
Optical Power in OMA	OMA	-2.1			dBm	
Side Mode Suppression Ratio	SMSR	30			dB	
Spectral Width (-20dB)	$\Delta\lambda$			0.3	nm	
Relative Intensity Noise	RIN			-128	dB/Hz	

Launch Power of OFF Transmitter	<i>POUT_OFF</i>			-30	dBm	1
Extinction Ratio	<i>ER</i>	8.2			dB	
Optical Return Loss Tolerance	<i>Ori</i>			21	dB	
Receiver						
Center Wavelength	<i>λr</i>	1260		1600	nm	
Average Receive Power	<i>RX_avg</i>	-15.8		-1	dBm	
Receiver Sensitivity in 10.3Gbps (OMA)	<i>Rsen1</i>			-14.1	dBm	
Stressed Receiver Sensitivity in 10.3Gbps (OMA)	<i>Rsen2</i>			-11.3	dBm	
Reflectance	<i>Rrx</i>			-26	dB	
LOS Asserted	<i>LOSA</i>	-28			dBm	
LOS De-Asserted	<i>LOSD</i>			-19	dBm	
LOS Hysteresis	<i>LOSH</i>	0.5			dB	

Notes:

1. Measured with conformance test signal for BER=10⁻¹². The stressed sensitivity values in the table are for systems level BER measurements which include the effects of CDR circuits. It is recommended that at least 0,4dB additional margin be allocated if component level measurements are made without the effects of CDRcircuits.

Electro Characteristics

<i>Parameter</i>	<i>Symbol</i>	<i>Min.</i>	<i>Typ.</i>	<i>Max.</i>	<i>Units</i>	<i>Note</i>
Data Rate	<i>MRA</i>	1	10.3	11.3	Gbps	
Input Differential Impedance	<i>RIN</i>		100		Ω	
Differential Data Input	<i>VtxDiff</i>	120		850	mV	
Transmit Disable Voltage	<i>VD</i>	2		Vcc3+0.3	V	
Transmit Enable Voltage	<i>VEN</i>	0		0.8	v	
Transmit Disable Assert Time	<i>VN</i>			100	us	
Receiver						
Data Rate	<i>MRA</i>		10.3	11.3	Gbps	
Differential Output Swing	<i>Vout P-P</i>	350		850	mV	
Rx Output Rise and Fall Time	<i>Tr/Tf</i>	24			ps	
LOS – Asserted	<i>VOA</i>	2		Vcc3+0.3	V	
LOS – Negated	<i>VOL</i>	0		0.4	V	

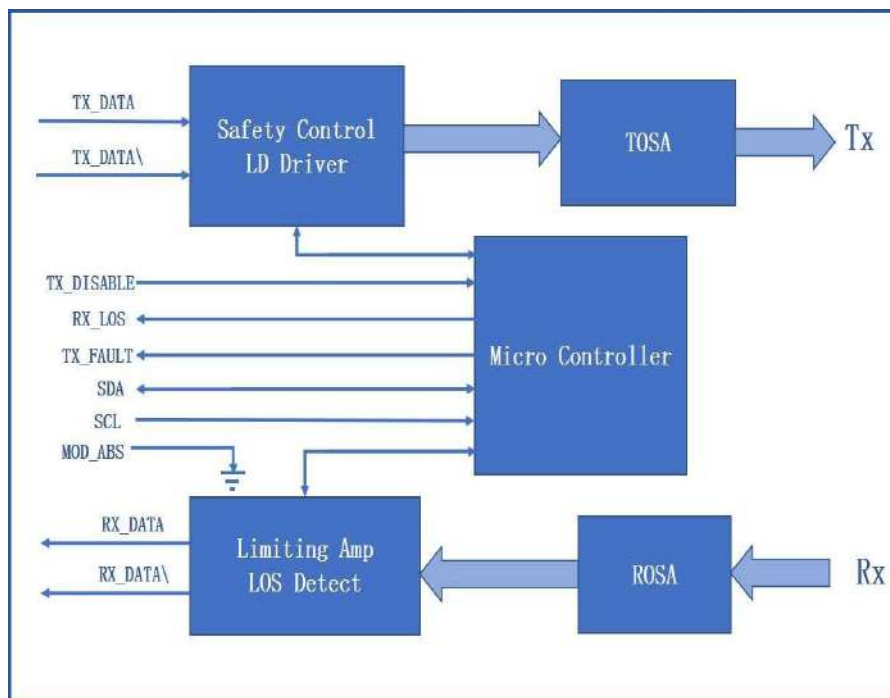
Block Diagram of Transceiver

Pin Assignment

Pin	Symbol	Function/Description	Notes
1	VEET	Transmitter Ground	1
2	Tx_FAULT	Transmitter Fault	2
3	Tx_DIS	Transmitter Disable. Laser output disabled on high or open	3
4	SDA	2-wire Serial Interface Data Line	2
5	SCL	2-wire Serial Interface Clock Line	2
6	MOD_ABS	Module Absent. Grounded within the module	4
7	RS0	Rate Select 0	5
8	RX_LOS	Loss of Signal indication. Logic 0 indicates normal operation	2
9	RS1	Rate Select 1	5
10	VEER	Receiver Ground	1
11	VEER	Receiver Ground	1
12	RD-	Receiver Inverted DATA out. AC Coupled	
13	RD+	Receiver DATA out. AC Coupled	
14	VEER	Receiver Ground	1
15	VCCR	Receiver Power Supply	
16	VCCT	Transmitter Power Supply	
17	VEET	Transmitter Ground	1
18	TD+	Transmitter DATA in. AC Coupled	
19	TD-	Transmitter Inverted DATA in. AC Coupled	
20	VEET	Transmitter Ground	1

Dimensions

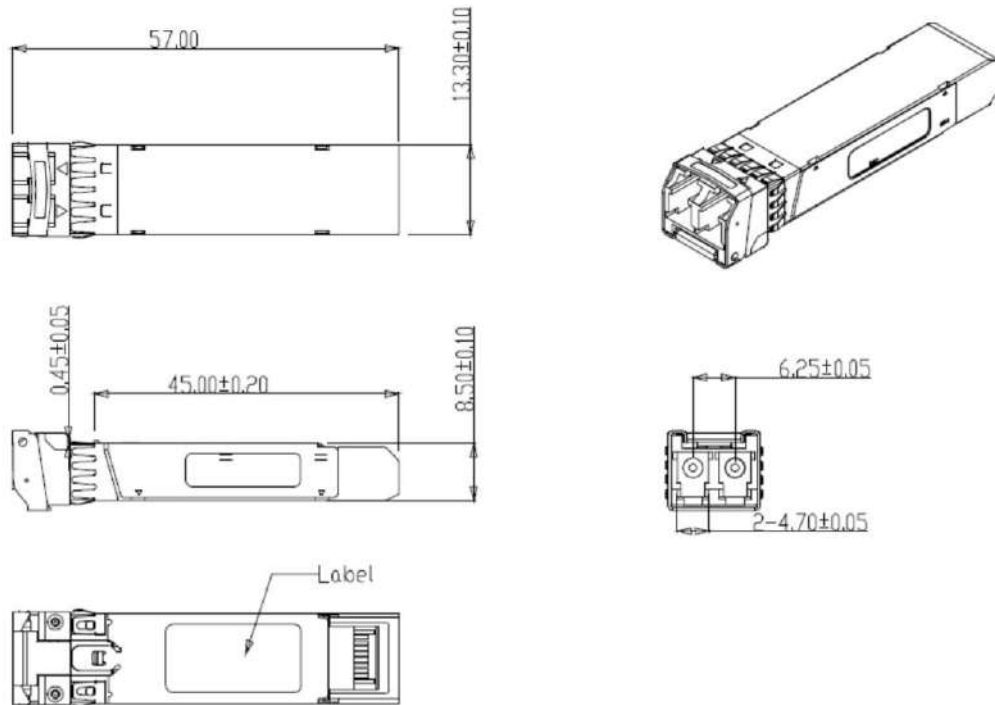

Optical Receptacle Cleaning Recommendations:

All fiber stubs inside the receptacle portions were cleaned before shipment. In the event of contamination of the optical ports, the recommended cleaning process is the use of forced nitrogen. If contamination is thought to have remained, the optical ports can be cleaned using a NTT international Cletop® stick type and HFE7100 cleaning fluid. Before the mating of patch-cord, the fiber end should be cleaned up by using Cletop® cleaning cassette.

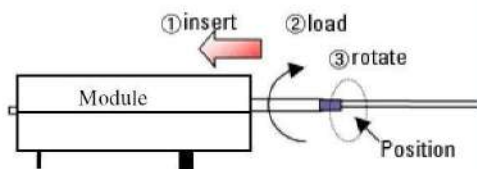
<p>Cleaning of patch-cord</p> 	<p>Cleaning of fiber stub</p>  <ol style="list-style-type: none"> 1. Insert Ensure that stick is held straight when inserting into sleeve. 2. Load Apply sufficient pressure (approx 600-700g) to ensure ferrule a little depressed in sleeve. 3. Rotate Rotate stick clockwise 4-5 times, while ensuring direct contact with ferrule end-face is maintained. <p><i>Notice: Number of possible wipes: Maintenance (repair) ~1 use / piece Equipment construction: 4 uses / piece (max.)</i></p>
--	---

Note: The pictures were extracted from NTT-ME website. And the Cletop® is a trademark registered by NTT-ME

Ordering Information

Model Number	Part Number	Wavelength	Temperature
ASFP-10G-ER15	OPAK-S40-15-CF	1550nm	-5°C ~70 °C

Note: All information contained in this document is subject to change without notice